

Pressure relief pilot operated poppet type and anti-cavitation valve with pressure cut-off stage Special cavity, FB

VBL1-16

VBL1.SFB

RE 18319-10

Edition: 11.2023

Replaces: 07.2023

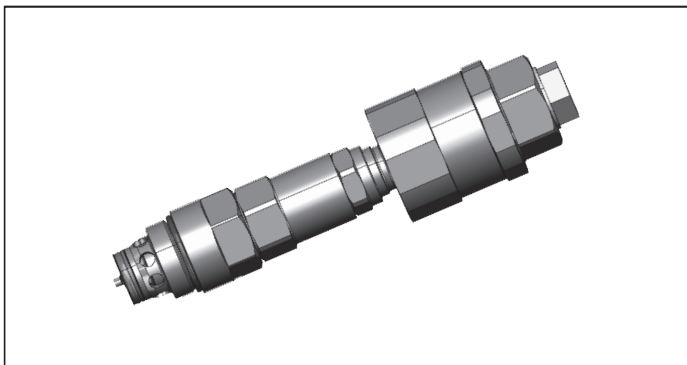

Technical data	
Max. operating pressure port 1 (P)	420 bar (6000 psi)
Max. pressure admitted port 2 (T)	50 bar (725 psi)
Max pilot pressure port 3 Pst	30 bar (435 psi)
Max. flow	100 l/min (63 gpm)
Max. internal leakage ¹⁾	15 drops/min.
Fluid temperature range	-20 to 120 °C (-4 to 248 °F) (Viton)
Installation torque ²⁾	90 Nm (66,4 ft-lbs)
Weight	0.55 kg (1.21 lbs)
Special cavity	FB (see data sheet 18325-75)
Lines bodies and standard assemblies	Please refer to section "Hydraulic integrated circuit" or consult factory
Seal kit (Viton) ³⁾	Code: RG16R2040520100 material no: R931002593
Fluids	Mineral-based or synthetics with lubricating properties at viscosities of 10 to 380 mm ² /s (cSt)
Recommended degree of fluid contamination	Nominal value max. 10µm (NAS 9) / ISO 4406 20/18/15
Installation position	No restrictions
MTTFD	150 years see RE 18350-51
Other Technical Data	See data sheet 18350-50
Without surface protection	In case of need of surface protection, please consult factory.

Description

Flow is blocked from 1 to 2 until pressure increases to meet the selected valve setting, lifting the conical, pilot-stage poppet from its seat. This action exhausts oil above the main-stage poppet (low-leakage, seat type), allowing it to shift and provide relief flow through 2 to tank. Pressure at 2 is additive to the relief setting of the valve.

The anti-cavitation function makes up for lacking oil volumes caused, for example, by leakage when pressure valves respond or in the case of leading loads. If the pressure at main port 1 is lower than the one at main port 2, the spool will be lifted out of its seat. Hydraulic fluid flows from main port 2 to main port 1. Pressure shut-off function occurs by connecting pilot oil pressure to the external port 3 Pst, so the pilot oil is pressurized. This reduces the preload of the main spring and the maximum set system pressure.

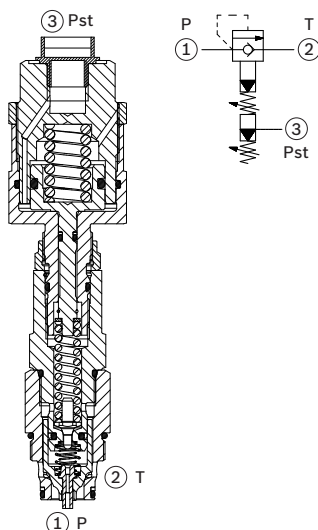

Characteristic curve

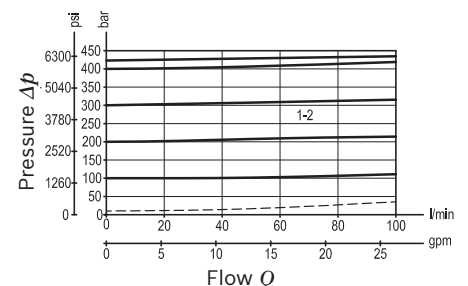
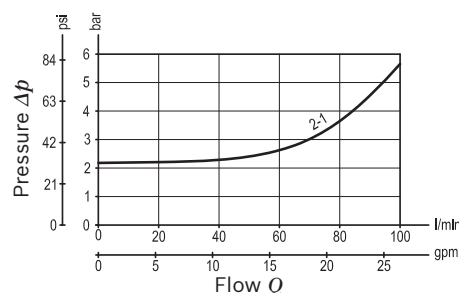

1) At 80% of pressure setting.

2) Torque value valid for installation in cast iron and steel manifolds. In case of different body materials, please consult factory.

3) Only external seals for 10 valves.

Ordering code

VBL1.SFB.VG	*
--------------------	----------

Pressure relief pilot operated poppet type and anti-cavitation valve with pressure cut-off stage

	SPRINGS		O-RING
	Maximum set pressure bar (psi)	Pressure increase bar/turn (psi/turn)	Material
000	420 (6090)	157 (2277)	Viton (FKM)

* Valves are delivered set at pressure setting <25 bar and with adjustment device not tighten. Fine setting to be done by customer. For case of request of factory set valve, please consult factory.

Preferred types

Type	Material number
VBL1.SFB.VG.000	R930077186

Type	Material number

Dimensions

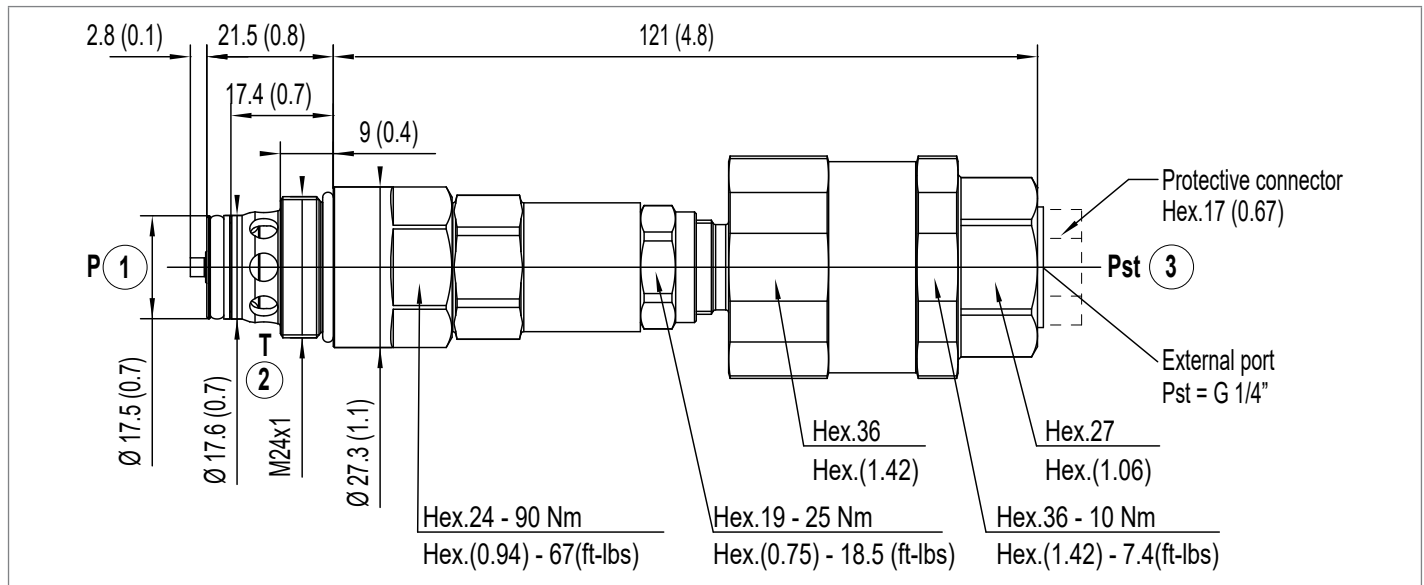

Bosch Rexroth Oil Control S.p.A.

Via Leonardo da Vinci 5
 P.O. Box no. 5
 41015 Nonantola – Modena, Italy
 Tel. +39 059 887 611
 Fax +39 059 547 848
 compact-hydraulics-cv@boschrexroth.com
 www.boschrexroth.com/compacthydraulics

© This document, as well as the data, specifications and other information set forth in it, are the exclusive property of Bosch Rexroth Oil Control S.p.a.. It may not be reproduced or given to third parties without its consent. The data specified above only serve to describe the product. No statements concerning a certain condition or suitability for a certain application can be derived from our information. The information given does not release the user from the obligation of own judgment and verification. It must be remembered that our products are subject to a natural process of wear and aging. Subject to change.