

# Pressure relief pilot operated poppet type and anti-cavitation valve Special cavity, FK

VMR3-32-FK

VMR3-FK

**RE 18318-44**

Edition: 07.2023

Replaces: 04.2022



Technical data	
Max. operating pressure port 1 (P)	420 bar (6000 psi)
Max. pressure admitted port 2 (T)	50 bar (725 psi)
Max. flow	400 l/min (106 gpm)
Max. internal leakage <sup>1)</sup>	75 drops/min.
Fluid temperature range	-20 to 120 °C (-4 to 248 °F) (Viton)
Installation torque <sup>2)</sup>	150 Nm (111 ft-lbs)
Weight	0.37 kg (0.82 lbs)
MTTFD	150 years see RE 18350-51
Special cavity	FK (see data sheet 18325-75)
Lines bodies and standard assemblies	Please refer to section "Hydraulic integrated circuit" or consult factory
Seal kit (Viton) <sup>3)</sup>	Code: RG32R2040540100 material no: R930077563
Fluids	Mineral-based or synthetics with lubricating properties at viscosities of 10 to 380 mm <sup>2</sup> /s (cSt)
Recommended degree of fluid contamination	Nominal value max. 10µm (NAS 9) / ISO 4406 20/18/15
Installation position	No restrictions
Other Technical Data	See data sheet 18350-50
Without surface protection	In case of need of surface protection, please consult factory.

## Description

Flow is blocked from 1 to 2 until pressure increases to meet the selected valve setting, lifting the conical, pilot-stage poppet from its seat. This action exhausts oil above the main-stage poppet (low-leakage, seat type), allowing it to shift and provide relief flow through 2 to tank. Pressure at 2 is additive to the relief setting of the valve.

The anti-cavitation function makes up for lacking oil volumes caused, for example, by leakage when pressure valves respond or in the case of leading loads. If the pressure at main port 1 is lower than the one at main port 2, the spool will be lifted out of its seat. Hydraulic fluid flows from main port 2 to main port 1.

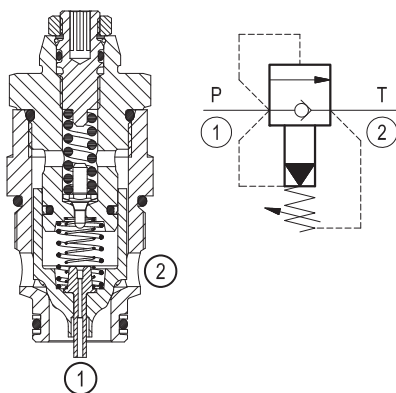

1) At 80% of pressure setting.

2) Torque value valid for installation in cast iron and steel manifolds. In case of different body materials, please consult factory.

3) Only external seals for 10 valves.

## Characteristic curve

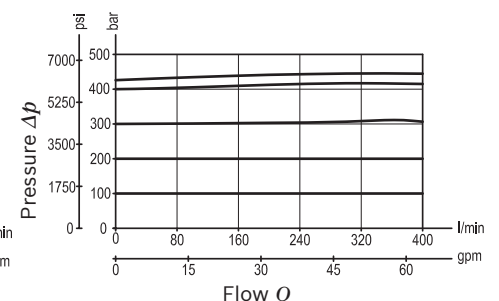
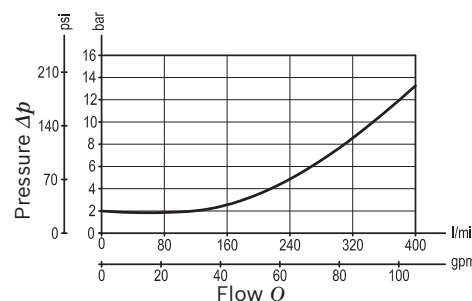

**Ordering code**

<b>VMR3.HFK</b>	<b>*</b>	<b>010</b>
-----------------	----------	------------

Pressure relief pilot operated poppet type and anti-cavitation valve

	SPRINGS		O-RING
	Adj. press. range bar (psi)	Pressure increase bar/turn (psi/turn)	Material
<b>VG</b>	100-420 (1450-6090)	300 (4350)	Viton (FKM)

\* Valves are delivered set at pressure setting <25 bar and with adjustment device not tighten. Fine setting to be done by customer. For case of request of factory set valve, please consult factory.

**Preferred types**

Type	Material number
VMR3.HFK.VG.010	R930071773

Type	Material number

**Dimensions**

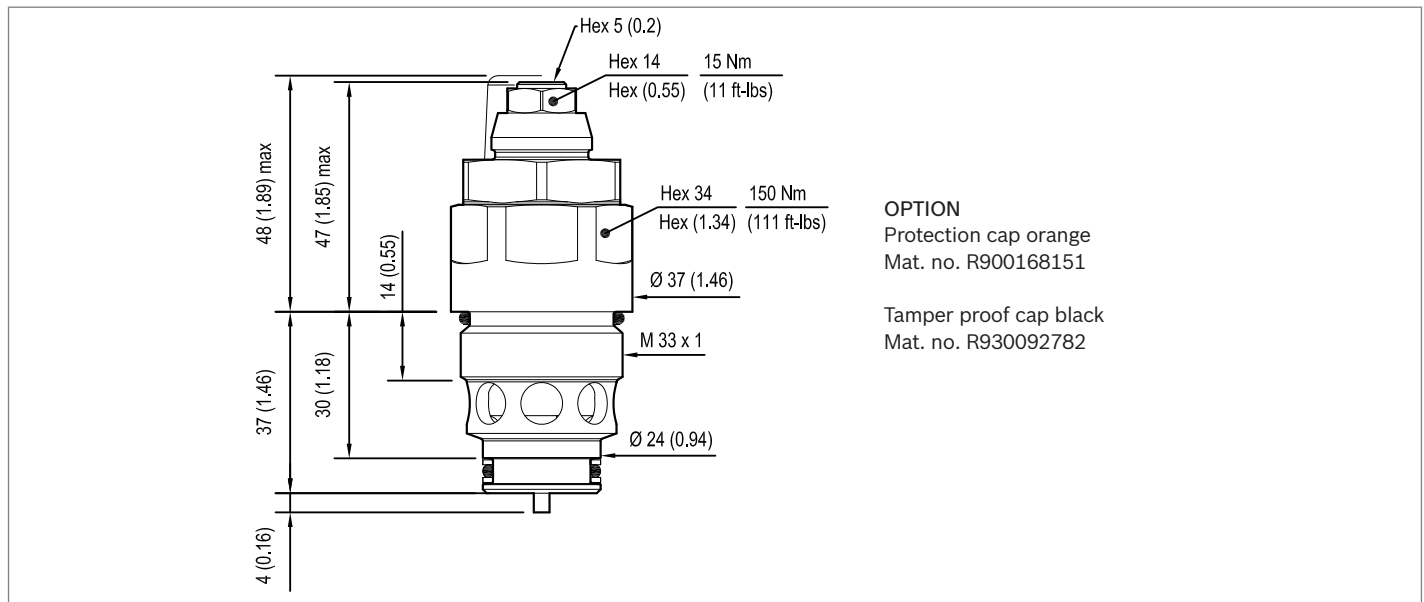

**Bosch Rexroth Oil Control S.p.A.**

Via Leonardo da Vinci 5  
P.O. Box no. 5  
41015 Nonantola – Modena, Italy  
Tel. +39 059 887 611  
Fax +39 059 547 848  
compact-hydraulics-cv@boschrexroth.com  
www.boschrexroth.com/compacthydraulics

© This document, as well as the data, specifications and other information set forth in it, are the exclusive property of Bosch Rexroth Oil Control S.p.a.. It may not be reproduced or given to third parties without its consent. The data specified above only serve to describe the product. No statements concerning a certain condition or suitability for a certain application can be derived from our information. The information given does not release the user from the obligation of own judgment and verification. It must be remembered that our products are subject to a natural process of wear and aging. Subject to change.