

6 to 14/2 ways/positions bankable flow diverters flangeable L739.... (VS270F)

RE 18302-12

Edition: 02.2016

Replaces: 05.2014



Size 8

Series 00

Maximum operating pressure 310 bar (4500 psi)

Maximum flow 80 l/min (21.1 gpm)

Ports G 3/8 - G 1/2 - SAE10

**NEW spool position sensor available for this valve.
See RE18300-30**

General specifications

- 6 way 2 position valve.
- Directional spool valve with direct solenoid control.
- Hydraulic / pneumatic pilot, or manual push and twist control available as option.
- Usable as stand-alone, or as multiple stackable units.
- Control spool operated by solenoid, with easily removable coil fastened by a ring nut.
- Wet pin tube for DC coil, with push rod for mechanical override in case of voltage shortage.
- Unrestricted 360° orientation of DC coil.
- Control spool held in normal position by return spring.
- Optional manual override (push-button or screw type).
- Connectors available: DIN 43650 – ISO 4400, AMP Junior, DT04-2P (Deutsch), Free leads.

Contents

Ordering details	2
Symbols	2
Functional description	3
Technical data	3
Characteristic curves	5
External dimensions and fittings	6
Electric connection	9

Ordering details

01	02	03	04	05	06	07	08	09
L	7	39						

Family

01	Compact directional valve	L
----	---------------------------	----------

Type

02	Flow diverters	7
----	----------------	----------

Ports

03	G 3/8 DIN 3852	3
	G 1/2 DIN 3852	2
	7/8-14 UNF (SAE10)	D

Control type

04	Solenoid (coil C48) without manual override	12
	Solenoid (coil C48) with push-button type manual override	2P
	Solenoid (coil C48) with screw type manual override	1F
	Hydraulic / pneumatic control ¹⁾	P1
	Manual push and twist control	H1

Spool variants

05	6 way / 2 position P1 side	6_
----	----------------------------	-----------

Drain type

06	Internal drain	6B	6H	I
				E
	External drain	•	-	

Voltage supply

07	Manual push and twist control	31	07	03	01	00	SG
	Without coil	-	-	-	-	•	00
	12 V DC	•	•	•	•	-	OB
	13 V DC	-	•	-	•	-	AD
	24 V DC	•	•	•	•	-	OC
	27 V DC	-	•	-	•	-	AC
	48 V DC	-	-	-	•	-	OD

Electric connections

08	Without coils	00
	With coils, without mating connector DIN EN 175301-803 ²⁾	01
	With coils, with bi-directional diode, without mating connector vertical Amp-Junior	03
	With coils, with bi-directional diode, without mating connector DT04-2P	07
	With coils and bipolar sheathed lead 350mm (13,8 in) long	31

Assembly

09	Single diverter	0
	2 Pre-assembled diverters	2
	3 Pre-assembled diverters	3
	4 Pre-assembled diverters	4
	5 Pre-assembled diverters	5

• = Available - = Not available

Symbols

Drain type I

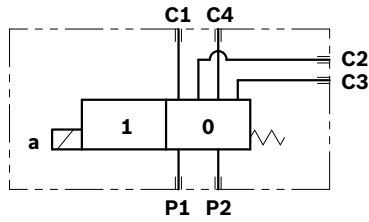

Drain type E

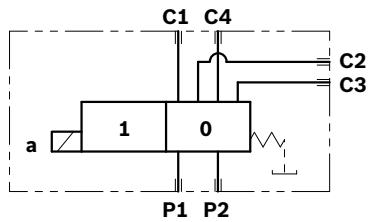

Spool variants

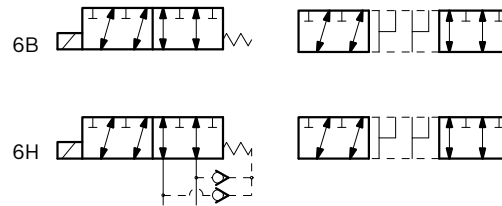

1) Minimum pressure 4 bar (58psi) with external drain (E), maximum pressure 200 bar (2901psi). With internal drain (I), at the minimum pressure (4 bar - 58psi), add the working pressure with ratio of 6,5:1. Example: With working pressure 100 bar (1450psi), minimum pilot pressure is 19.38 bar (281psi) ((100:6,5) + 4 bar (58psi)).

2) For connectors ordering code see data sheet RE 18325-90.

Functional description

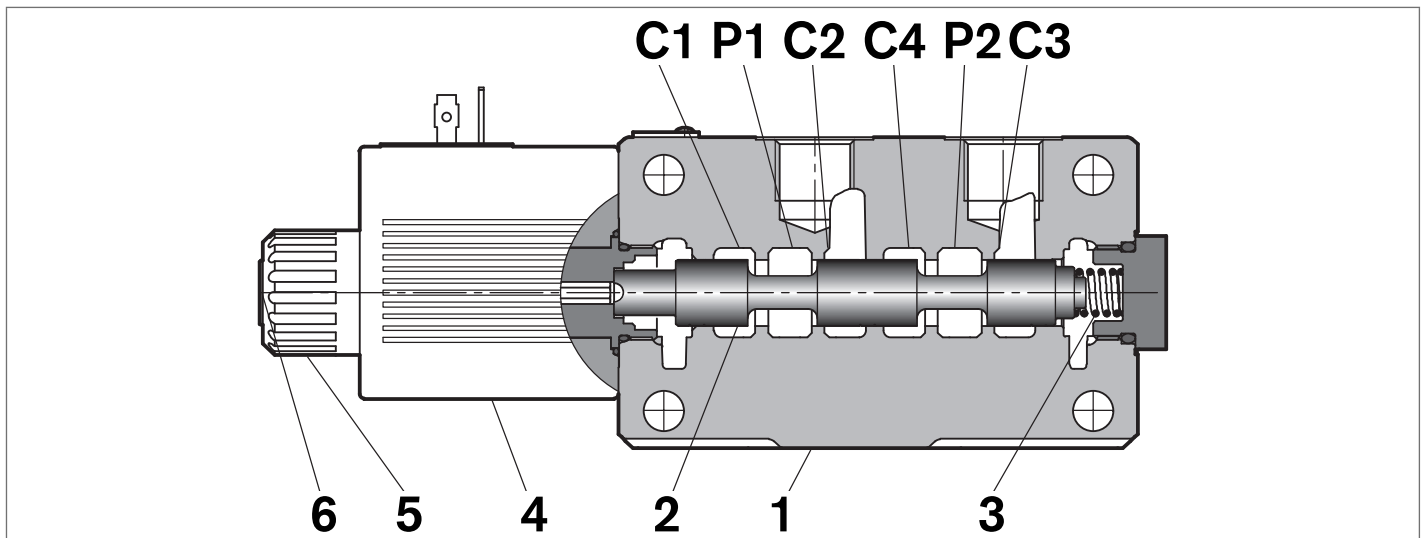

A valve basically consists of a housing (1), a control spool (2), a return spring (3) and a solenoid (5). It is designed to connect two inlet lines P1 – P2 (normally a set of hoses) and divert them to either the outlet ports (C1 – C4) with spool in position “0”, when the solenoid is de-energized, or to the outlet ports (C2 – C3) with spool in position “1”, when the solenoid is energized.

With the coil de-energized, the return spring (3) pushes

back the spool (2) and holds it in position “0”.

The coil (5) is fastened to the tube by the ring nut (6).

The manual override (6) allows to shift the spool (2) also in case of voltage shortage.

An external drain, to be connected to tank, ensures shifting operations also at higher working pressure.

Hydraulic / pneumatic pilot control, or manual push and twist control for spool shifting are available upon request.

Technical data

General		
Valve weight	kg (lbs)	3.2 (7.06)
Mounting position		unrestricted
Ambient Temperature	°C (°F)	-20....+50 (-4....+122) (NBR seals)
Hydraulic		
Maximum pressure with external drain (“E” type)	bar (psi)	310 (4500)
Maximum pressure with internal drain (“I” type)	bar (psi)	250 (3625)
Maximum pressure with internal drain and 6H scheme		310 (4500)
Maximum inlet flow	l/min (gpm)	80 (21.1)
Hydraulic fluid		
General properties: it must have physical lubricating and chemical properties suitable for use in hydraulic systems such as, for example:		Mineral oil based hydraulic fluids HL (DIN 51524 part 1). Mineral oil based hydraulic fluids HLP (DIN 51524 part 2). For use of environmentally acceptable fluids (vegetable or polyglycol base) please consult us.
Fluid Temperature	°C (°F)	-20....+80 (-4....+176) (NBR seals)
Permissible degree of fluid contamination		ISO 4572: $\beta_x \geq 75$ X = 12...15 ISO 4406: class 20/18/15 NAS 1638: class 9
Viscosity range	mm ² /s	5....420
Internal leakage with 100 bar (1450 psi) secondary pressure at C	cc/min (in ³ /min)	min.10 (0.61) max. 20 (1.22)

4 **L739.... (VS270F)** | 6 to 14/2 ways/positions bankable flow diverters flangeable
 Technical data

Electrical						
Voltage type		DC				
Voltage tolerance (nominal voltage)	%	-10 +10				
Duty		Continuous, with ambient temperature ≤ 50°C (122°F)				
Coil wire temperature not to be exceeded	°C (°F)	150 (302)				
Insulation class		H				
Compliance with		Low Voltage Directive LVD 73/23/EC (2006/95/EC), 2004/108/EC				
Coil weight with DIN 43650 – ISO 4400 connector	kg (lbs)	0.5 (1.1)				
Voltage	V	12	13	24	27	48
Voltage type		DC	DC	DC	DC	DC
Power consumption	W	36	36	36	36	36
Current (nominal at 20 °C (68 °F))	A	3.0	2.77	1.53	1.32	0.75
Resistance (nominal at 20 °C (68 °F))	Ω	3.97	4.68	15.67	20.42	63.60

Note

For applications with different specifications consult us

Code	Voltage [V]	Connector type	Coil description	Marking	Coil Mat no.
OB 01	12 DC	EN 175301-803 (Ex. DIN 43650)	C4801 12DC	12 DC	R933000063
OB 03	12 DC	AMP JUNIOR	C4803 12DC	12 DC	R933000065
OB 07	12 DC	DEUTSCH DT 04-2P	C4807 12DC	12 DC	R933000068
OB 31	12 DC	Cable 350 mm long	C4831 12DC	12 DC	R933000064
AD 01	13 DC	EN 175301-803 (Ex. DIN 43650)	C4801 13DC	13 DC	R933000069
AD 07	13 DC	DEUTSCH DT 04-2P	C4807 13DC	13 DC	R933000073
OC 01	24 DC	EN 175301-803 (Ex. DIN 43650)	C4801 24DC	24 DC	R933000076
OC 03	24 DC	AMP JUNIOR	C4803 24DC	24 DC	R933000071
OC 07	24 DC	DEUTSCH DT 04-2P	C4807 24DC	24 DC	R933000075
OC 31	24 DC	Cable 350 mm long	C4831 24DC	24 DC	R933000070
AC 01	27 DC	EN 175301-803 (Ex. DIN 43650)	C4801 27DC	27 DC	R933000077
AC 07	27 DC	DEUTSCH DT 04-2P	C4807 27DC	27 DC	R933000074
OD 01	48 DC	DIN EN 175301-803 ISO 4400	C4801 48DC	48 DC	R933000078

Characteristic curves

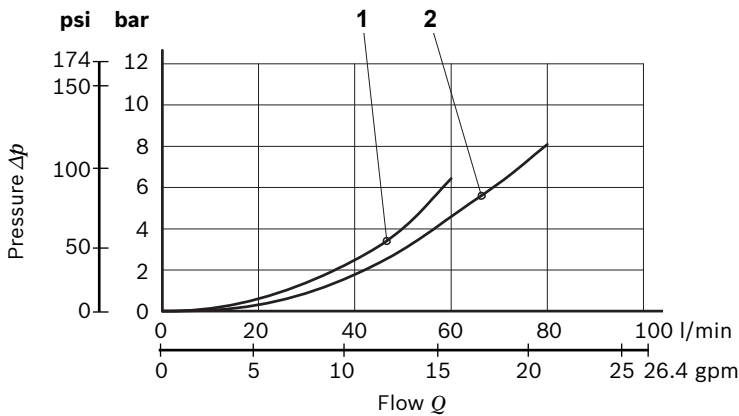

Model	Curve no.			
	P1>C1	P1>C2	P2>C4	P2>C3
VS270-G3/8	1	1	1	1
VS270-G1/2	2	2	2	2
VS270-SAE10	2	2	2	2

Measured with hydraulic fluid ISO-VG32 at 45° ±5 °C (113° ±9 °F); ambient temperature 20 °C (68 °F).

DI-DE performance limits

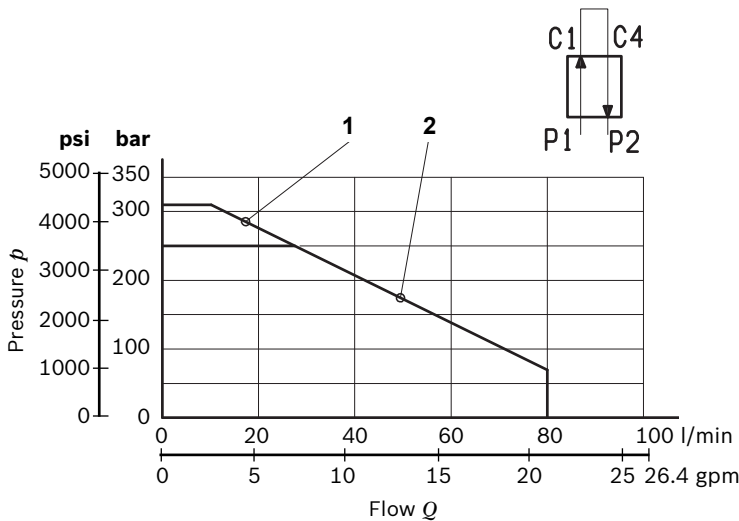

Scheme	Internal Drain	External Drain
v6B	2	1
6H	1	-

The performance curves are measured with flow going across and coming back, like P1>C1 and C4>P2.

External dimensions and fittings

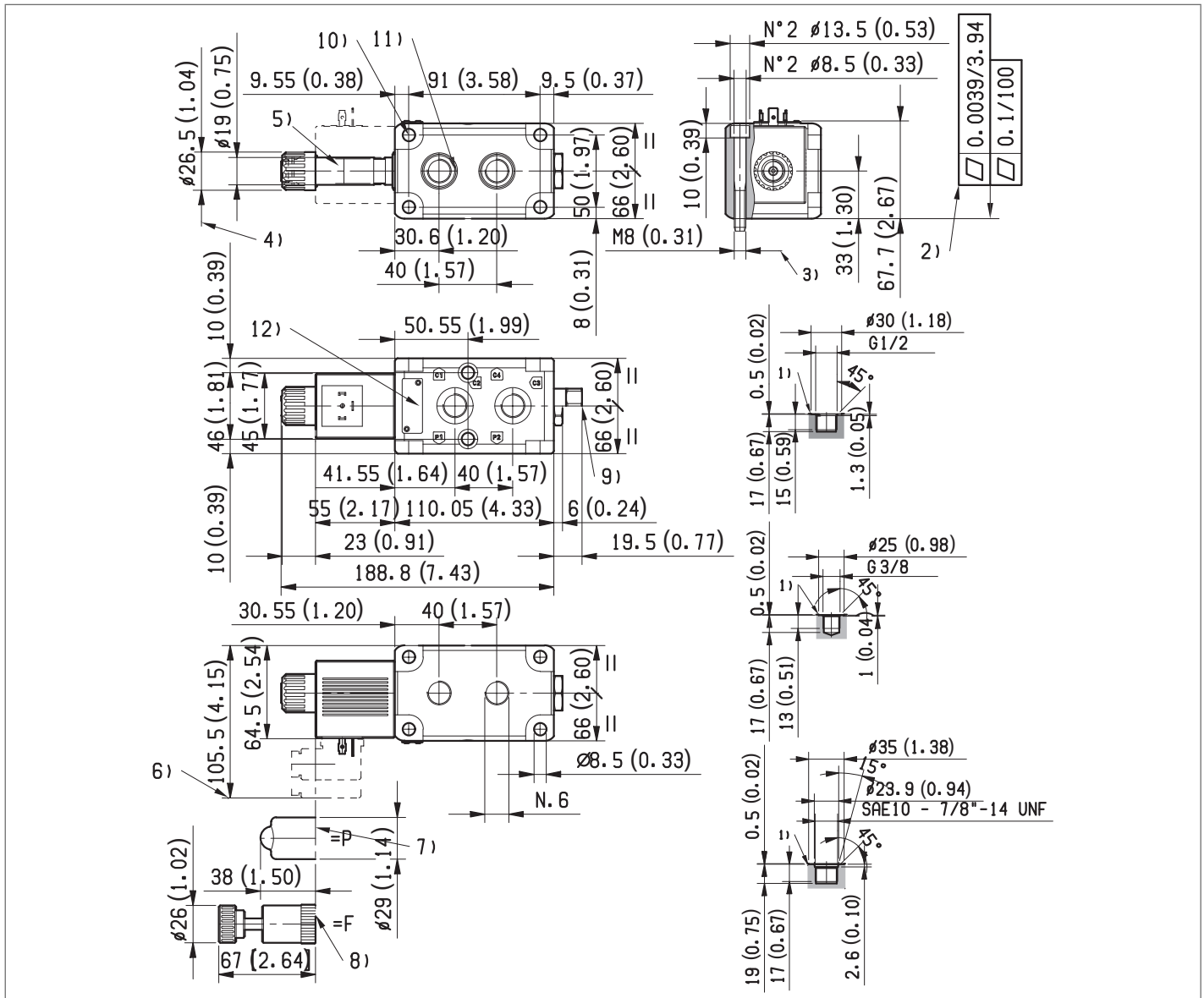

- | | |
|--|---|
| <p>1 Ports P1, P2, C1, C2, C3, C4.</p> <p>2 The mounting surface flatness must comply with specifications.</p> <p>3 Two through installation holes recommended screws M8x65 with strength class DIN 8.8.
Torque 15 – 16 Nm (11,1-11,8 ft-lb).</p> <p>4 Ring nut for coil locking Ø 26.5 mm (1.04 inch).
Torque 5-6 Nm (3.6-4.4 ft-lb).</p> <p>5 Solenoid tube Ø 19 mm (0.75 inch).</p> <p>6 Minimum clearance needed for connector removal.</p> <p>7 Optional push-button, 2P type, manual override for spool opening: it is pressure stuck to the ring nut for coil locking.
Mat no. R933000043.</p> <p>8 Optional screw type manual override, 1F type, for spool opening: it is screwed (torque 6-7Nm (4.4-5.2 ft-lb)) to the tube as replacement of the coil ring nut. Mat no. R933007215.</p> <p>9 External drain plug available with G 1/4 and SAE 4 port.</p> <p>10 Four through holes, 8.5 mm dia., for coupling of other similar diverter valve.</p> | <p>11 O-Ring (NBR) for P1 and P2 ports.</p> <p>12 Identification label.</p> |
|--|---|

Dimensions [mm (inches)]

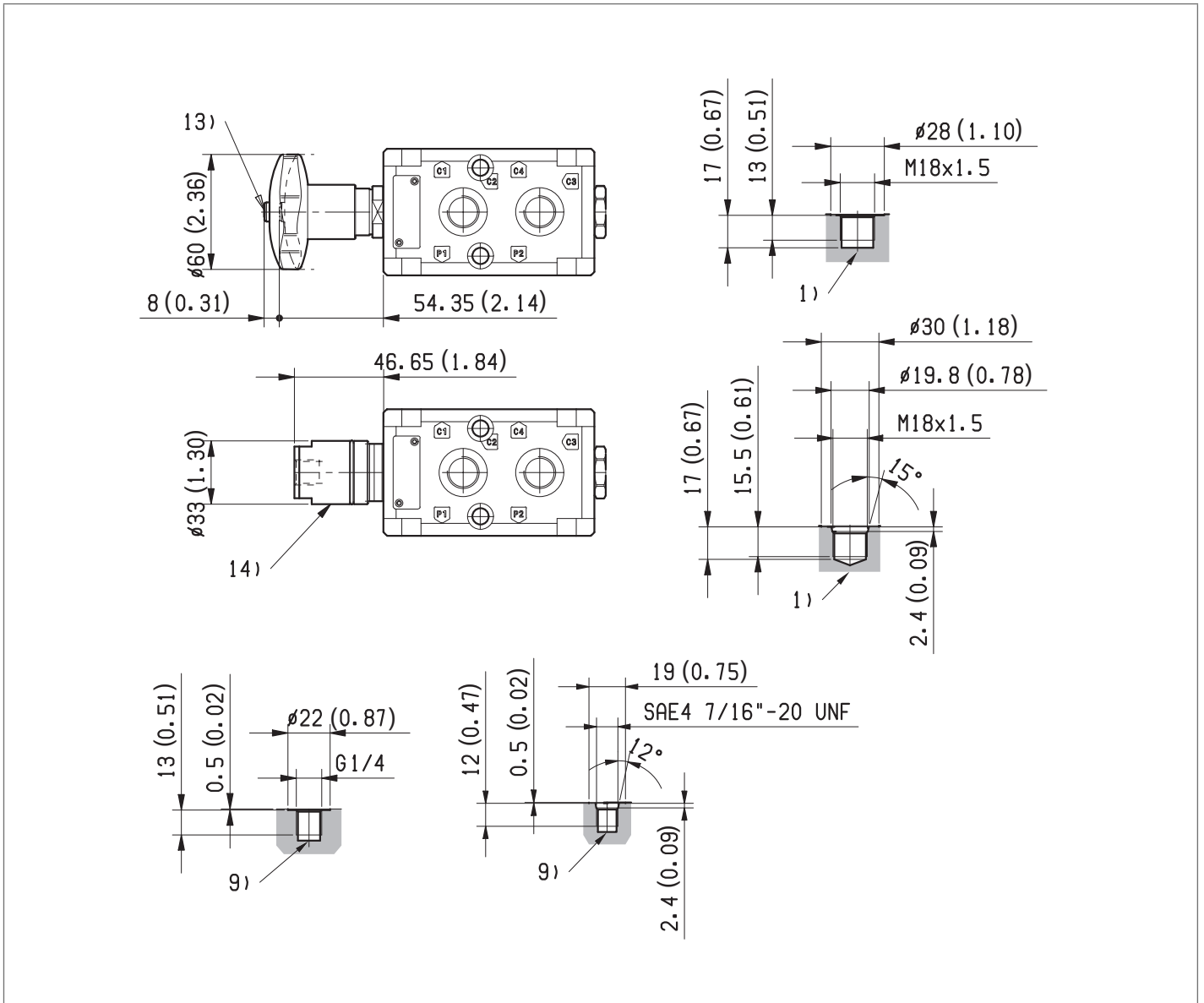

- 1** Ports P1, P2, C1, C2, C3, C4.
- 13** Dimensions of manual version, push and twist type.
- 14** Dimensions of hydraulic / pneumatic piloted version.
Pilot port plug available with G 1/4.

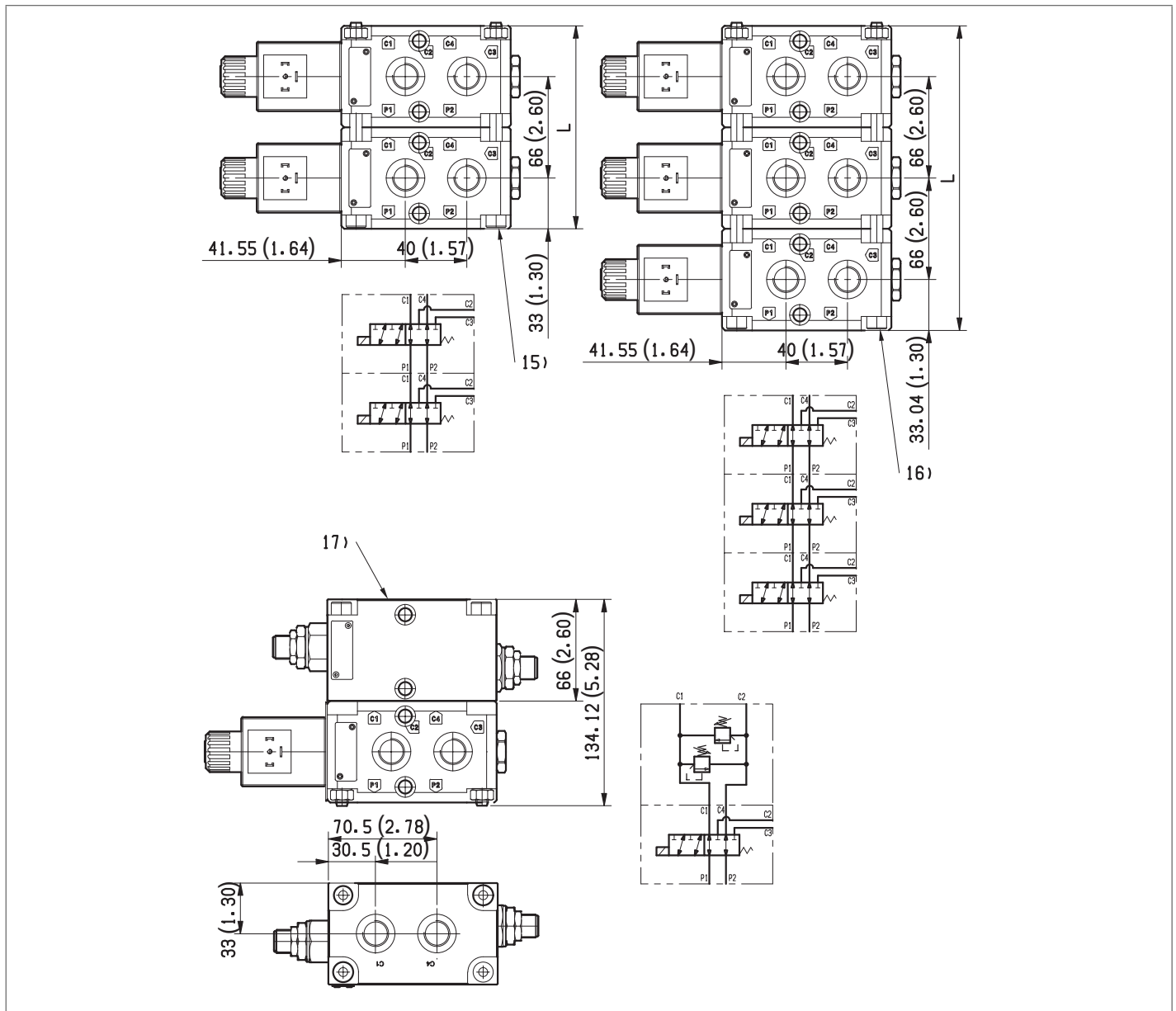

15 Four screws M8x125 DIN 912 for coupling together 2 diverter valves. Suggested bolt strength class DIN 8.8. Torque 16 – 18 Nm (11.8-13.3 ft-lb).

16 Four screws M8x190 DIN 912 for coupling together 3 diverter valves. Suggested bolt strength class DIN 8.8.

Torque 16-18 Nm (11.-13.3 ft lb).

17 Modular relief valves (cartridges VMD1040SV):
 with G 3/8 ports, code L7313610214SV00
 with SAE 8 ports, code L731C610214SV00.
 Max pressure 250 bar (3625psi).

Total stacked units	Total Ports	Total length	Bolts (v) or Tie Rods (t)	Torque Nm / (ft-lb)
2	8	132 (5.2)	M8x125 (v)	16-18 / (11.8-13.2)
3	10	198 (7.8)	M8x190 (v)	16-18 / (11.8-13.2)
4	12	264 (10.4)	M8x270 (t)	16-18 / (11.8-13.2)
5	14	330 (13.0)	M8x330 (t)	16-18 / (11.8-13.2)

Dimensions [mm (inches)]

Electric connection

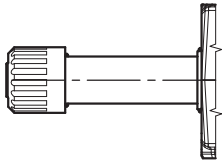
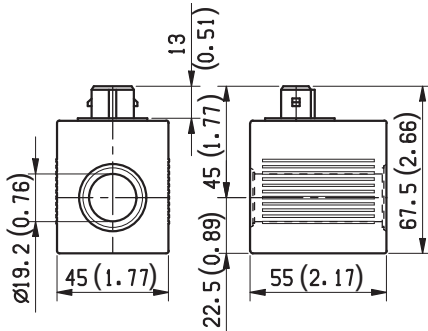
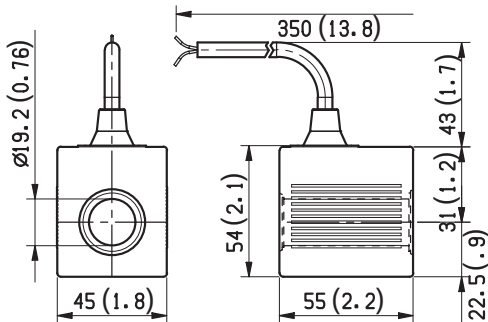
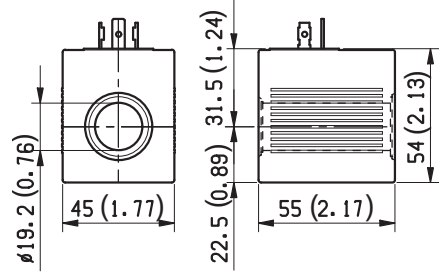
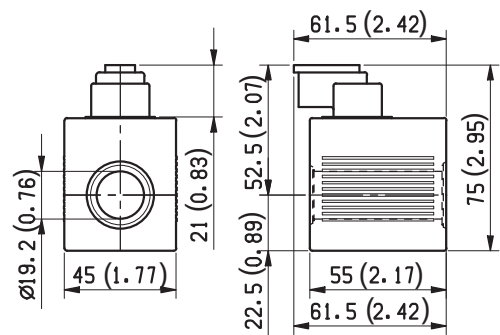
Electric connection**00****03** Protection class: IP 65 with female connector properly fitted (see drawing).**31****01****07** Protection class: IP 69 K with female connector properly fitted (see drawing).

Bosch Rexroth Oil Control S.p.A.

Oleodinamica LC Division
Via Artigianale Sedrio, 12
42030 Vezzano sul Crostolo
Reggio Emilia - Italy
Tel. +39 0522 601 801
Fax +39 0522 606 226 / 601 802
compact-hydraulics-cdv@boschrexroth.com
www.boschrexroth.com/compacthydraulics

© This document, as well as the data, specifications and other information set forth in it, are the exclusive property of Bosch Rexroth Oil Control S.p.a.. It may not be reproduced or given to third parties without its consent. The data specified above only serve to describe the product. No statements concerning a certain condition or suitability for a certain application can be derived from our information. The information given does not release the user from the obligation of own judgment and verification. It must be remembered that our products are subject to a natural process of wear and aging.
Subject to change.