

Intermediate Elements

Intermediate elements with double acting hand pump

EPM-DE-18

RE 18301-20

Edition: 09.2018

Replaces: 02.2016

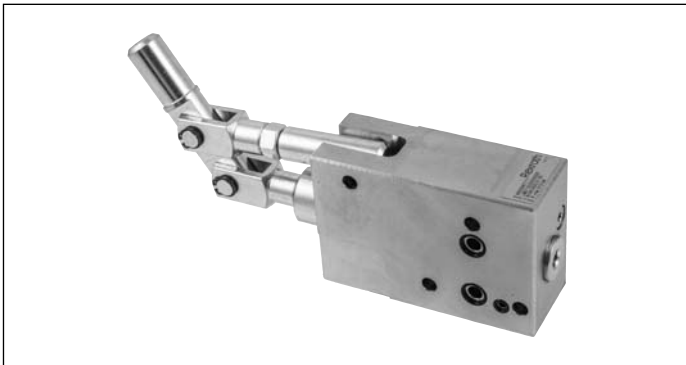

Description

It is recommended to install this intermediate plate with auxiliary hand pump between the inlet plate and the ED modular directional valves.

It is also recommended that the intermediate plate with auxiliary hand pump is under head.

When used with LS directional valve, please provide a mean to close the LS signal going to the pump.

When used with open center compensator (e.g. TE-06) select a compensator that can be locked in closed position.

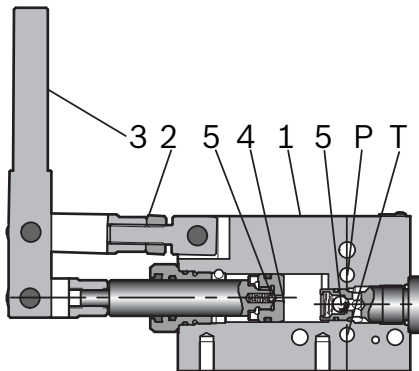

Technical data

General		
Weight of the EPM (hand pump slice)	kg (lbs)	3.7 (8.2)
Weight of the extension lever	kg (lbs)	0.7 (1.5)
Ambient Temperature	°C (°F)	-20....+50 (-4....+122) (NBR seals)
Hydraulic		
Maximum resistance pressure	bar (psi)	310 (4500)
Maximum generated pressure	bar (psi)	250 (3625)
Total displacement	cc (in ³)	18 (1.08)
Opening displacement	cc (in ³)	8.5 (0.51)
Closing displacement	cc (in ³)	9.5 (0.57)
Maximum aspiration height	m (ft)	1.5 (4.92) (with pipe DN6)
Hydraulic fluid General properties: it must have physical lubricating and chemical properties suitable for use in hydraulic systems such as, for example:		Mineral oil based hydraulic fluids HL (DIN 51524 part 1). Mineral oil based hydraulic fluids HLP (DIN 51524 part 2). For use of environmentally acceptable fluids (vegetable or polyglycol base) please consult us.
Fluid Temperature	°C (°F)	-20....+80 (-4....+176) (NBR)
Permissible degree of fluid contamination		ISO 4572: $\beta_{x \geq 75} X = 12 \dots 15$ ISO 4406: class 20/18/15 NAS 1638: class 9
Viscosity range	mm ² /s	5....420
Maximum internal leakage	cc/min (in ³ /min)	0.2 (0.012)

Note

For applications with different specifications consult us.

Symbol

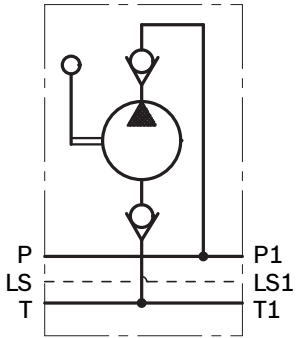

Characteristic curves

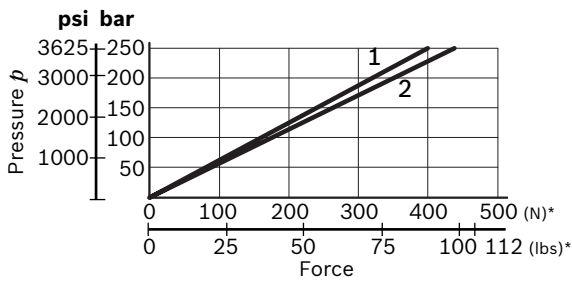

1: Opening stroke.

2: Closing stroke.

* Force applied by operator using our extension lever, length 457.5 mm (18 inch).

Ordering details

Code	Description	Material Number
L88710000000000	HAND PUMP ED (LEVER POINTING UP)	R930067711
L88710000000001	EXTENTION LEVER FOR HAND PUMP ED	R930067712
L88710000000002	HAND PUMP ED (LEVER POINTING DOWN)	R930069614

External dimensions and fittings

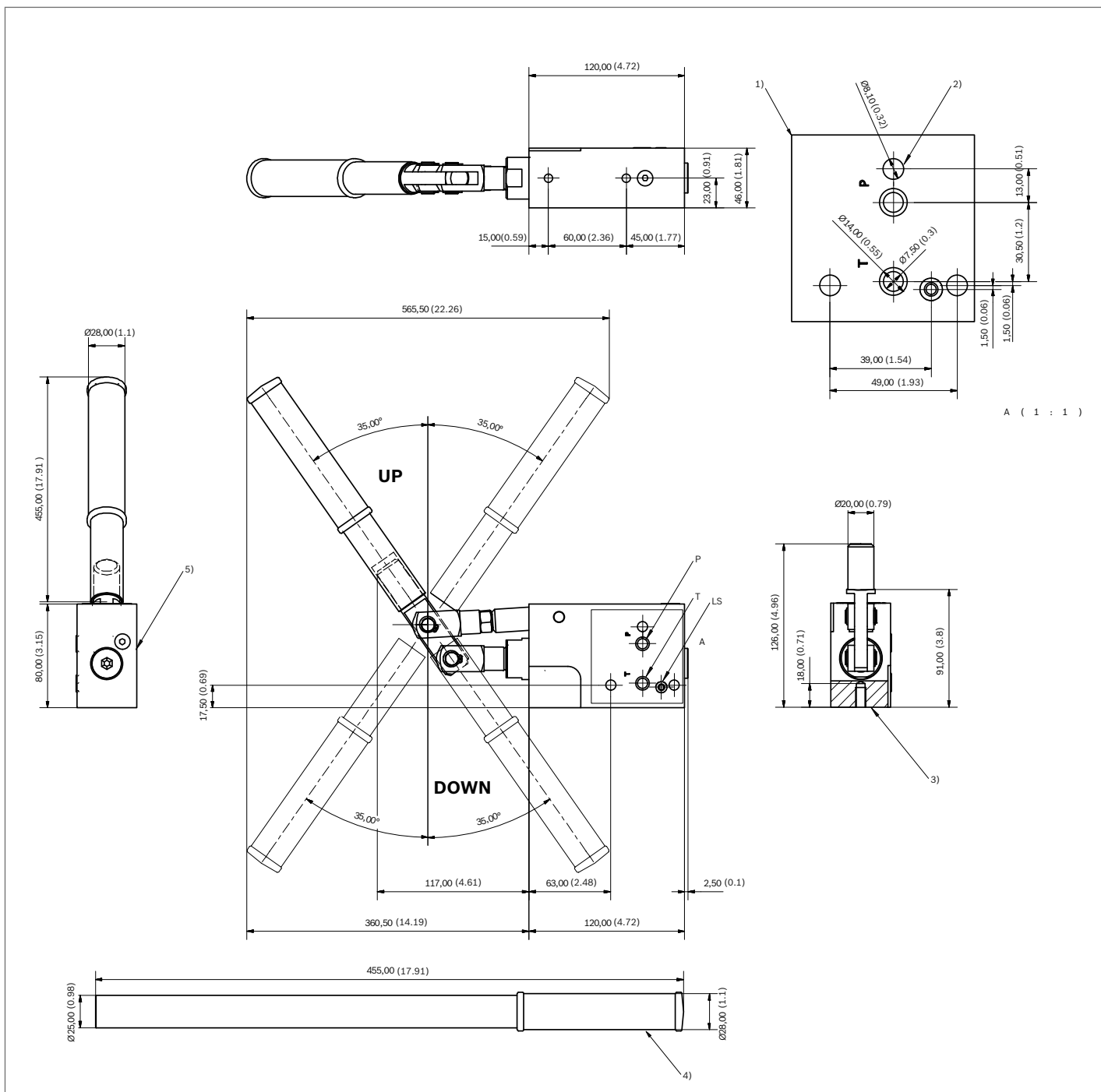

1 Flange specifications for coupling to ED intermediate elements.
2 For tie rod and tightening torque information see data sheet RE 18301-90.

3 N° 2 Fixing Hole. M8. tightening torque 35-40 Nm. (26-29.5ft-lbs).
4 Optional extension lever. (See ordering code).
5 Side of position of inlet plate.

Bosch Rexroth Oil Control S.p.A.

Oleodinamica LC Division
Via Artigianale Sedrio, 12
42030 Vezzano sul Crostolo
Reggio Emilia - Italy
Tel. +39 0522 601 801
Fax +39 0522 606 226 / 601 802
compact-hydraulics-cdv@boschrexroth.com
www.boschrexroth.com/compacthydraulics

© This document, as well as the data, specifications and other information set forth in it, are the exclusive property of Bosch Rexroth Oil Control S.p.a.. It may not be reproduced or given to third parties without its consent. The data specified above only serve to describe the product. No statements concerning a certain condition or suitability for a certain application can be derived from our information. The information given does not release the user from the obligation of own judgment and verification. It must be remembered that our products are subject to a natural process of wear and aging.
Subject to change.