

## 4/3 and 4/2 on-off directional valve elements with or without secondary relief valves and with or without LS connections

D8\_5... (EDD-XZ)

**RE 18301-12**

Edition: 02.2016

Replaces: 07.2012

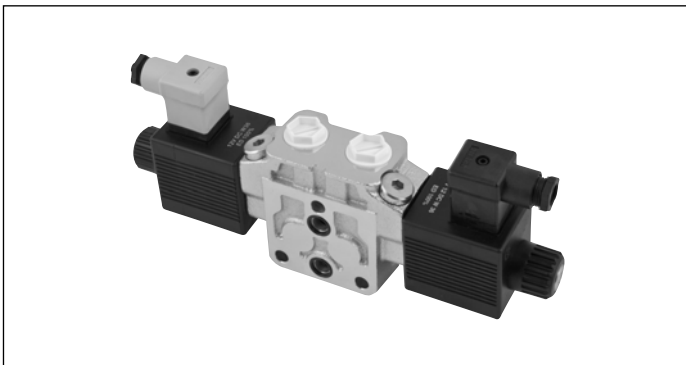

Size 8

Series 00

Maximum pressure (pump side) 310 bar (4500 psi)

Maximum pressure (actuator side) 380 bar (5500 psi)

Maximum flow 80 l/min (21.1 gpm)

Port connections G 1/2 - SAE10 - Flangeable

**NEW spool position sensor available for this valve.  
See RE18300-30**

### General specifications

Valve elements with solenoid operated directional spool.  
Control spools directly operated by solenoids with  
removable coils.

In the de-energized condition, the control spool is held  
in the central position by return springs.

Wet pin tubes for DC coils, with push rod for mechanical  
override; zinc plated surface.

Coils can be rotated 180° around the tube; they can be  
energized by AC current through special connection  
with rectifier (RAC).

Manual override (push-button, screw type) available as  
option.

Different plug-in connectors available: see ordering  
details.

### Contents

Ordering details	2
Functional description	4
Technical data	5
Characteristic curves	7
External dimensions and fittings	8
Electric connection	10

## Ordering details

01	02	03	04	05	06	07	08	09	10	11
<b>D</b>	<b>8</b>		<b>5</b>						<b>0</b>	

<b>Family</b>		
01	Directional Valve elements EDD	<b>D</b>

<b>Type</b>		
02	Size 8	<b>8</b>

<b>Configuration</b>		
03	Standard	<b>0</b>
	With channels for Load Sens.	<b>4</b>

<b>Coil type</b>		
04	C48	<b>5</b>

<b>Spool variants<sup>1)</sup></b>		
05	4/3 operated on both sides a and b	<b>2</b>
	4/2 operated on side a only	<b>3</b>
	4/2 operated on side b only	<b>4</b>

<b>Voltage supply</b>		<b>31</b>	<b>07</b>	<b>03</b>	<b>01</b>	<b>00</b>	
06	Without coil	-	-	-	-	-	<b>00</b>
	12V DC	●	●	●	●	-	<b>OB</b>
	13V DC	-	●	-	●	-	<b>AD</b>
	24V DC	●	●	●	●	-	<b>OC</b>
	27V DC	-	●	-	●	-	<b>AC</b>
	48V DC	-	-	-	●	-	<b>OD</b>
	24V AC (21.5 DC)	-	-	-	●	-	<b>OV</b>
	110V AC (98 DC)	-	-	-	●	-	<b>OW</b>
	230V AC (207 DC)	-	-	-	●	-	<b>OZ</b>

<b>Electric connections</b>		
07	Without coils	<b>00</b>
	With coils, without mating connector DIN EN 175301-803	<b>01</b> <sup>4)</sup>
	With coils, with bi-directional diode, without mating connector vertical Amp-Junior	<b>03</b>
	With coils, with bi-directional diode, without mating connector DT04-2P	<b>07</b>
	With coils and bipolar sheathed lead 350mm (13,8 in) long	<b>31</b>

<b>Ports</b>		
08	G 1/2 DIN 3852	<b>2</b>
	SAE 10	<b>D</b>
	Flangeable (A-B-T)	<b>M</b>

<b>Secondary valve on A port <sup>2)</sup></b>		
09	Without secondary valve	<b>0</b>
	Anti-cavitation function valve VUM	<b>1</b> <sup>5)</sup>
	Relief direct acting valve with anti-cavitation function VMA <sup>3)</sup> (for setting see table below)	-

<b>Secondary valve on B port <sup>2)</sup></b>		
10	Without secondary valve	<b>0</b>
	Anti-cavitation function valve VUM	<b>1</b> <sup>5)</sup>
	Relief direct acting valve with anti-cavitation function VMA <sup>3)</sup> (for setting see table below)	-

<b>Options</b>		
11	No options	<b>No code</b>
	Push-button type manual override	<b>OP</b>
	Screw type manual override	<b>OF</b>

● = Available    - = Not available

## Symbols

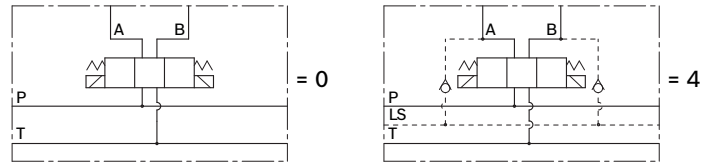

## Secondary valves possible configurations

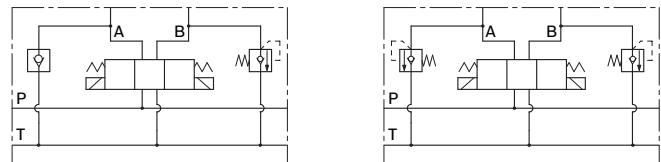
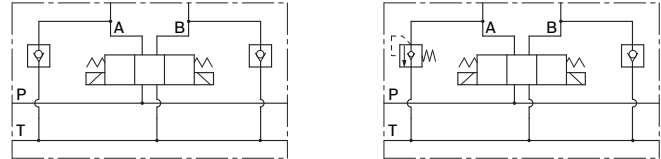

## Flangeable version =M

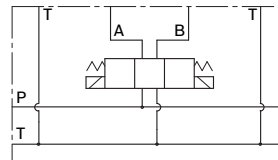

A	B	C	D	E	F	G	H	I	J	K	L
20 bar	30 bar	40 bar	50 bar	60 bar	70 bar	80 bar	90 bar	100 bar	110 bar	120 bar	130 bar
290 psi	435 psi	580 psi	725 psi	870 psi	1015 psi	1160 psi	1305 psi	1450 psi	1595 psi	1740 psi	1885 psi

M	N	O	P	Q	R	S	T	U	V	W	X
140 bar	150 bar	160 bar	170 bar	180 bar	190 bar	200 bar	210 bar	220 bar	230 bar	240 bar	250 bar
2030 psi	2175 psi	2320 psi	2465 psi	2611 psi	2756 psi	2901 psi	3046 psi	3191 psi	3336 psi	3481 psi	3626 psi

1) The required hydraulic symbol and spool variant can be chosen by consulting page 2.

2) The use of the secondary valve in one ports implies the use of secondary valve in both ports.

3) The relief direct acting valve have a maximum flow capacity of 30 l/min (7.93 gpm).

For the characteristic curves see data sheet RE18329-11.

4) For connectors ordering code see data sheet RE 18325-90.

5) For the Characteristic curves see data sheet RE18329-51.

Spool variant

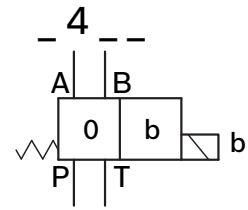
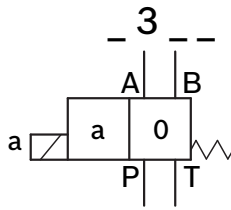
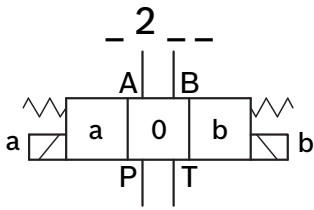

B201=				=K201
E201=				=E2R1
B301=				=B401
E301=				=E401
K301=				=K401
X301=				=X401
Y301=				=Y401

## Functional description

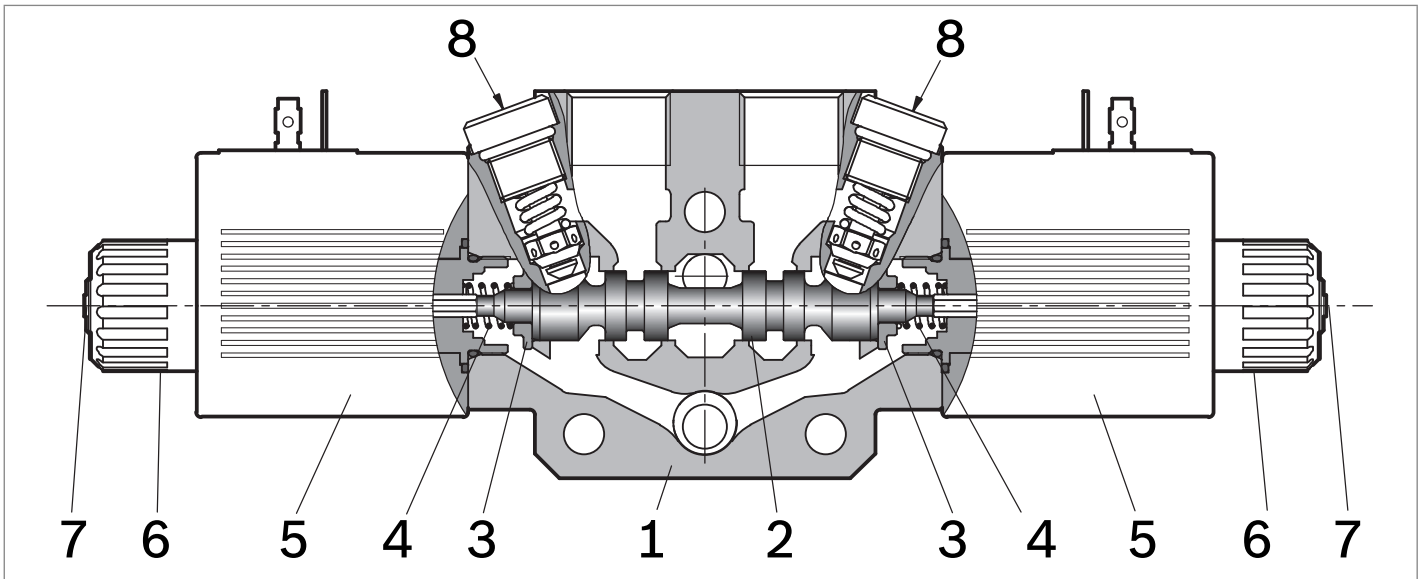

The sandwich plate design directional valve elements D8\_5 are compact direct operated solenoid valves which control the start, the stop and the direction of the oil flow. These elements basically consist of a stackable housing (1) with a control spool (2), one or two solenoids (5), and one or two return springs (4). The spring chamber are connected to the tank port. When the coil is energized, the spool (2) travels and oil is pushed to tank from one of the spring chambers: if the cross section of the orifices changes, the switching time changes as well. Three orifice sizes are available: smaller orifice results in longer switching time, even though the actual time is dependent upon pressure, flow and viscosity. When energized, the force of the

solenoid (5) pushes the control spool (2) from its neutral-central position to the required position, and the required flow from P to A (with B to T), or P to B (with A to T) is achieved. Once the solenoid is de-energized, the return spring (4) pushes the spool thrust washer (3) back against the housing and the spool returns in its neutral-central position. Each coil is fastened to the solenoid tube by a ring nut (6). A pin (7) allows to push the spool (2) in emergency conditions, when the solenoid cannot be energized, like in case of voltage shortage. The secondary cartridge valves are designed for quick response and stable pressure control (8); they also incorporate a reverse flow check for anti-cavitation.

**Technical data**

<b>General</b>									
Valve element with 2 solenoids	kg (lbs)	3.00 (6.61)							
Valve element with 1 solenoid	kg (lbs)	2.35 (5.18)							
Ambient Temperature	°C (°F)	-20....+50 (-4....+122) (NBR seals)							
<b>Hydraulic</b>									
Maximum pressure at P	bar (psi)	310 (4500)							
Maximum pressure at A and B ports	bar (psi)	380 (5500)							
Maximum pressure at T	bar (psi)	250 (3625)							
Maximum inlet flow	l/min (gpm)	80 (21.1)							
Hydraulic fluid		Mineral oil based hydraulic fluids HL (DIN 51524 part 1). Mineral oil based hydraulic fluids HLP (DIN 51524 part 2). For use of environmentally acceptable fluids (vegetable or polyglycol base) please consult us.							
General properties: it must have physical lubricating and chemical properties suitable for use in hydraulic systems such as, for example:									
Fluid Temperature	°C (°F)	-20....+80 (-4....+176) (NBR seals)							
Permissible degree of fluid contamination		ISO 4572: $\beta_{x \geq 75} X=12...15$ ISO 4406: class 20/18/15 NAS 1638: class 9							
Viscosity range	mm <sup>2</sup> /s	5....420							
<b>Electrical</b>									
Voltage type		DC (AC only with RAC connection)							
Voltage tolerance (nominal voltage)	%	-10 .... +10							
Duty		Continuous, with ambient temperature $\leq 50^{\circ}\text{C}$ (122°F)							
Coil wire temperature not to be exceeded	°C (°F)	150 (302)							
Insulation class		H							
Compliance with		Low Voltage Directive LVD 73/23/EC (2006/95/EC), 2004/108/EC							
Coil weight with connection EN 175301-803	kg (lbs)	0.5 (1.1)							
Voltage	V	12	13	24	27	48	24 +RAC (21,5)	110 +RAC (98)	230 +RAC (207)
Voltage type		DC	DC	DC	DC	DC	AC	AC	AC
Power consumption	W	36	36	36	36	36	36	36	36
Nominal 100% current	A	3.00	2.77	1.53	1.32	0.75	1.70	0.37	0.17
Coil resistance (nominal at 20°C (68°F))	$\Omega$	3.97	4.68	15.67	20.42	63.6	12.61	261	1163

**Note**

For applications with different specifications consult us

6 **D8\_5... (EDD-XZ)** | 4/3 and 4/2 on-off directional valve elements  
 Technical data

<b>Code</b>	<b>Voltage [V]</b>	<b>Connector type</b>	<b>Coil description</b>	<b>Marking</b>	<b>Coil Mat no.</b>
<b>OB 01</b>	12 DC	EN 175301-803 (Ex. DIN 43650)	C4801 12DC	12 DC	R933000063
<b>OB 03</b>	12 DC	AMP JUNIOR	C4803 12DC	12 DC	R933000065
<b>OB 07</b>	12 DC	DEUTSCH DT 04-2P	C4807 12DC	12 DC	R933000068
<b>OB 31</b>	12 DC	Cable 350 mm long	C4831 12DC	12 DC	R933000064
<b>AD 01</b>	13 DC	EN 175301-803 (Ex. DIN 43650)	C4801 13DC	13 DC	R933000069
<b>AD 07</b>	13 DC	DEUTSCH DT 04-2P	C4807 13DC	13 DC	R933000073
<b>OC 01</b>	24 DC	EN 175301-803 (Ex. DIN 43650)	C4801 24DC	24 DC	R933000076
<b>OC 03</b>	24 DC	AMP JUNIOR	C4803 24DC	24 DC	R933000071
<b>OC 07</b>	24 DC	DEUTSCH DT 04-2P	C4807 24DC	24 DC	R933000075
<b>OC 31</b>	24 DC	Cable 350 mm long	C4831 24DC	24 DC	R933000070
<b>AC 01</b>	27 DC	EN 175301-803 (Ex. DIN 43650)	C4801 27DC	27 DC	R933000077
<b>AC 07</b>	27 DC	DEUTSCH DT 04-2P	C4807 27DC	27 DC	R933000074
<b>OD 01</b>	48 DC	EN 175301-803 (Ex. DIN 43650)	C4801 48DC	48 DC	R933000078
<b>OV 01</b>	24 RAC	EN 175301-803 (Ex. DIN 43650)	C4801 21.5DC	21.5 DC	R933000079
<b>OW 01</b>	110 RAC	EN 175301-803 (Ex. DIN 43650)	C4801 98DC	98 DC	R933000080
<b>OZ 01</b>	230 RAC	EN 175301-803 (Ex. DIN 43650)	C4801 207DC	207 DC	R933000081

## Characteristic curves

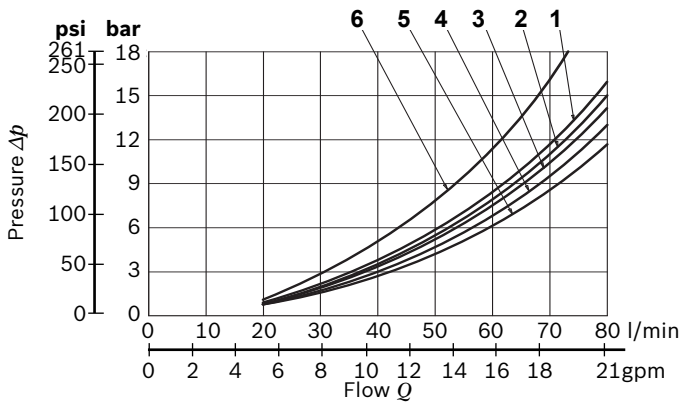

Spool Variant	Curve no.			
	P>A	P>B	A>T	B>T
B201 - B301 - B401	4	4	4	4
E201 - E301 - E401	3	3	5	5
K201 - K301 - K401	3	3	5	2
E2R1	3	6	5	-
X301 - X401	2	2	5	5
Y301 - Y401	2	2	1	1

Measured with hydraulic fluid ISO-VG32 at  $45^\circ \pm 5^\circ \text{C}$  ( $113^\circ \pm 9^\circ \text{F}$ ); ambient temperature  $20^\circ \text{C}$  ( $68^\circ \text{F}$ ).

## Performance limits

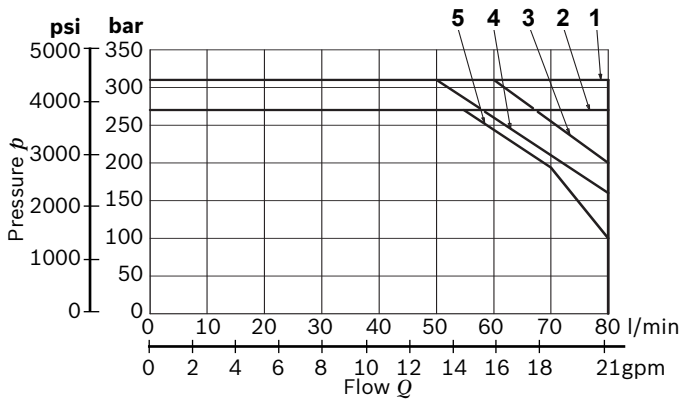

Spool Variant	Curve no.
B201 - B301 - B401	1
E201 - E301 - E401	4
K201 - K301 - K401	3
E2R1	3
X301 - X401	2
Y301 - Y401	5

The performance curves are measured with flow going across and coming back, like P>A and B>T, with symmetrical flow areas.

In case of special circuit connections, the performance limits can change.

**External dimensions and fittings**

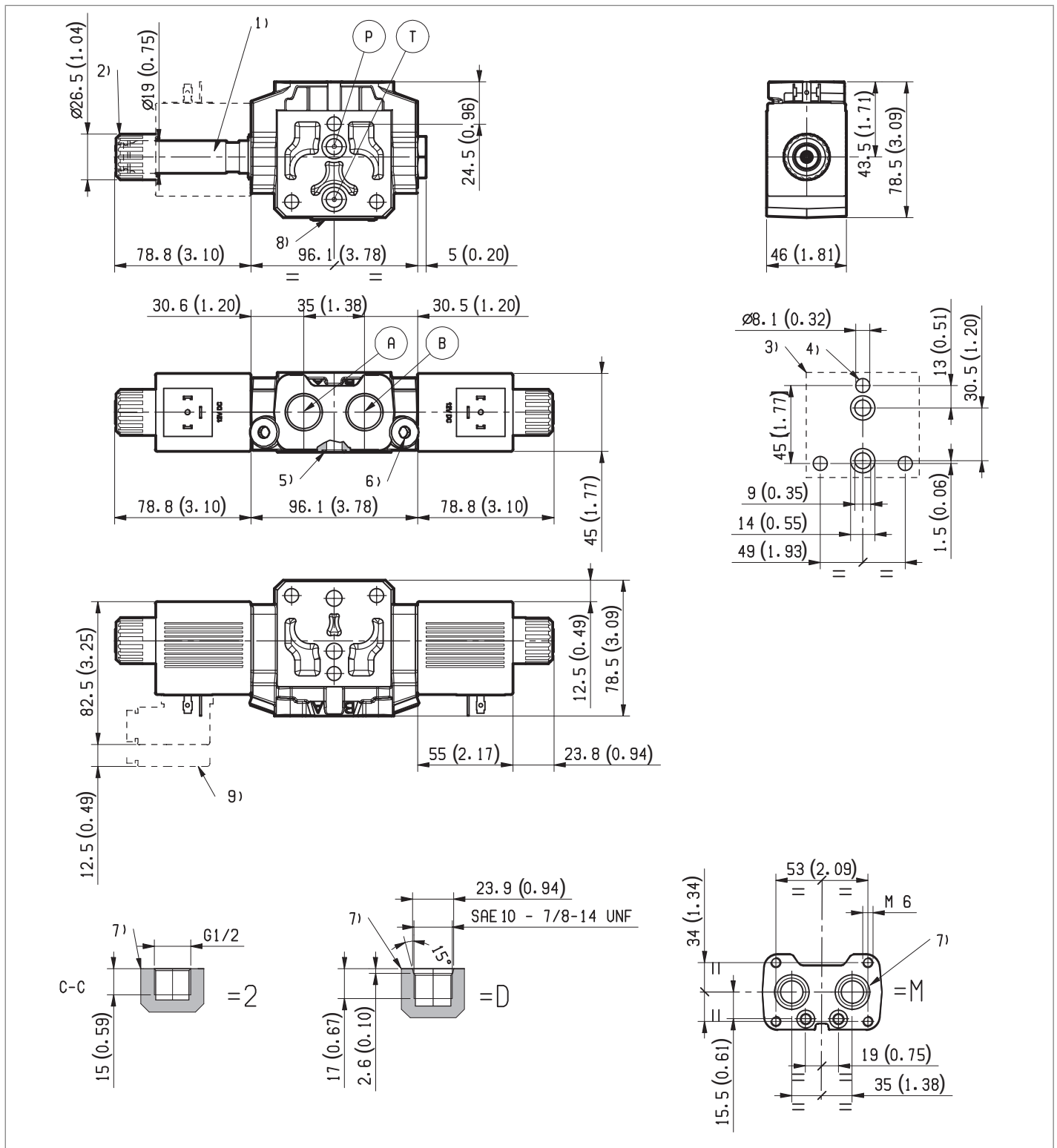

- |   |  |
|---|--|
| <ul style="list-style-type: none"> <li>1 Solenoid tube <math>\varnothing</math> 19mm (0.75 inch).</li> <li>2 Ring nut for coil locking (<math>\varnothing</math> 26,5mm); torque 5 Nm <math>\pm</math> 10% (3.68 <math>\pm</math> 10% ft-lb).</li> <li>3 Flange specification for coupling to ED intermediate elements.</li> <li>4 For tie rod and tightening torque information see data sheet RE 18301-90.</li> </ul> | <ul style="list-style-type: none"> <li>5 O-Rings for P and T ports.</li> <li>6 Secondary Pressure relief valve, hex 6mm (0.236 inch), torque 25-30 Nm (19-22 ft-lb).</li> <li>7 A and B ports.</li> <li>8 Identification label.</li> <li>9 Clearance needed for connection removal.</li> </ul> |
|---|--|



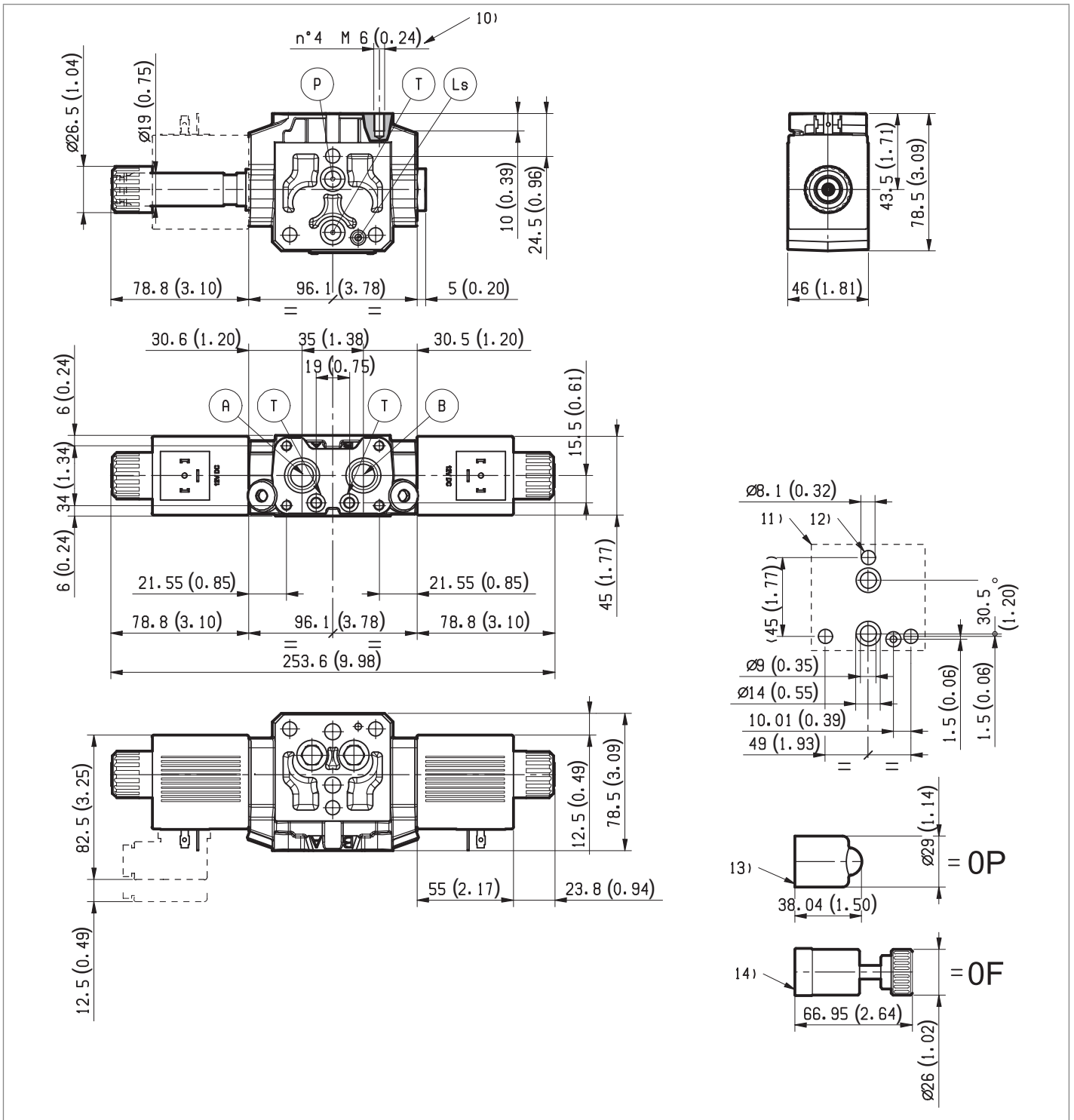

- 10** Four threaded M6 for fitting secondary flangeable elements. Bolts M6 with minimum recommended strength class DIN8.8. Torque 9-10 Nm (6.6-7.4 ft-lb).
- 11** Flange specification for coupling to the ED intermediate elements with LS channels.
- 12** For tie rod and tightening torque information see data sheet RE 18301-90.

- 13** Optional push-button manual override, OP type, for spool opening: it is pressure stuck to the ring nut for coil locking. Mat no R933000043.
- 14** Optional screw manual override, OF type, for spool opening: it is screwed (torque 6-7 Nm (4.4-5.2 ft-lb)) to the tube as replacement of the coils ring nut. Mat no. R933000022.

**Electric connection**

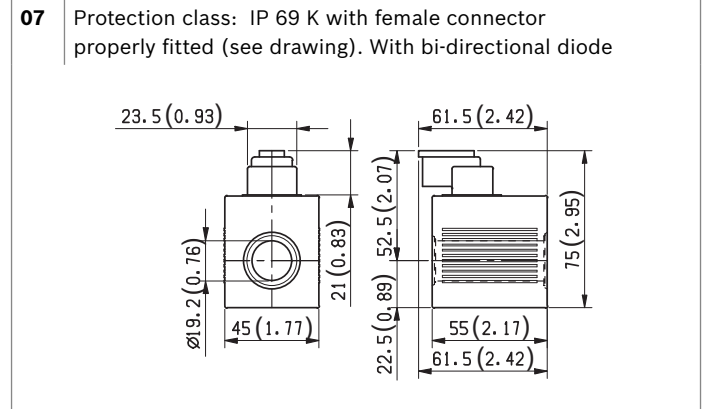
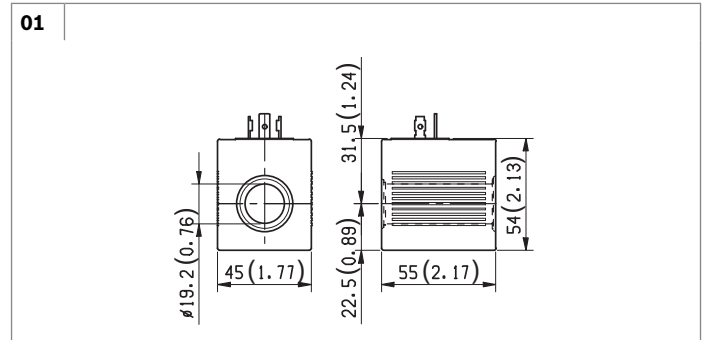
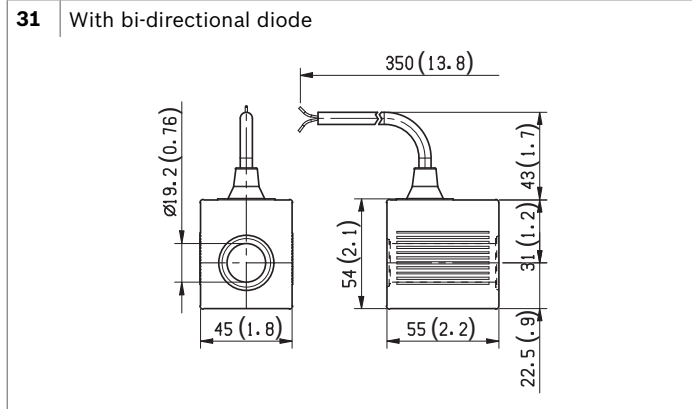
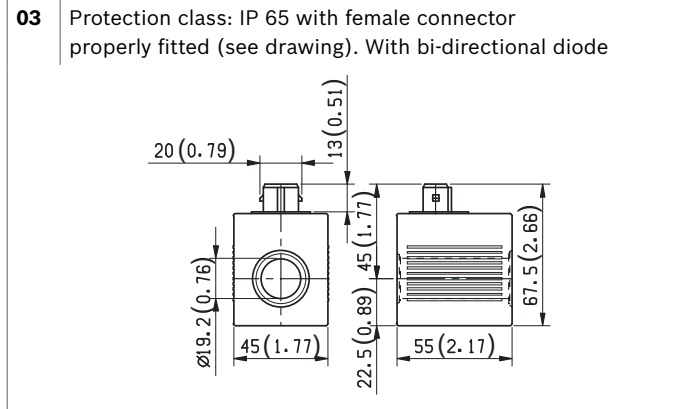
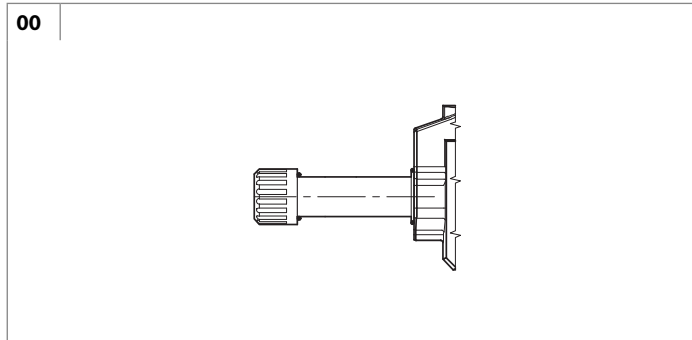

**Bosch Rexroth Oil Control S.p.A.**

Oleodinamica LC Division  
Via Artigianale Sedrio, 12  
42030 Vezzano sul Crostolo  
Reggio Emilia - Italy  
Tel. +39 0522 601 801  
Fax +39 0522 606 226 / 601 802  
compact-hydraulics-cdv@boschrexroth.com  
www.boschrexroth.com/compacthydraulics

© This document, as well as the data, specifications and other information set forth in it, are the exclusive property of Bosch Rexroth Oil Control S.p.a. It may not be reproduced or given to third parties without its consent. The data specified above only serve to describe the product. No statements concerning a certain condition or suitability for a certain application can be derived from our information. The information given does not release the user from the obligation of own judgment and verification. It must be remembered that our products are subject to a natural process of wear and aging. Subject to change.