

Insert type, Relief, direct acting poppet type

Special cavity, 730-A



VSA1.050

0T.M2.01 - X - 99 - Z - W

Dimensions

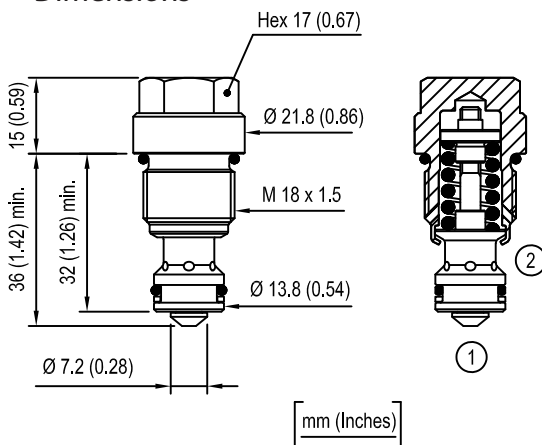

Description

Flow is blocked from 2 to 1 until pressure increases to meet the selected valve setting, lowering the poppet from its seat and allowing relief flow through port 1 to tank.

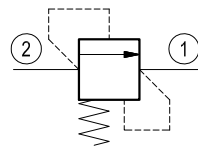

Technical data

Max. operating pressure (*)	bar (psi)	380 (5500)
Max. flow	l/min. (gpm)	50 (13)
Max. internal leakage (**)	drops/min.	15
Fluid temperature range	°C (°F)	-30 to 100 (-22 to 212)
Installation torque	Nm (ft-lbs)	45-50 (33-37)
Weight	kg (lbs)	0.07 (0.15)
Special cavity		730-A see data sheet RE 18325-75
MTTFd		150 years see data sheet 18350-51
Lines bodies and standard assemblies		Please refer to section "Hydraulic integrated circuit" or consult factory
Seal kit (***)	code material no.	RG730A020520100 R931002404
Fluids		Mineral-based or synthetics with lubricating properties at viscosities of 10 to 500 mm ² /s (cSt)
Recommended degree of fluid contamination		Nominal value max. 10µm (NAS 8) ISO 4406 20/18/15
Installation		No restrictions
Other Technical Data		See data sheet RE 18350-50

Performance

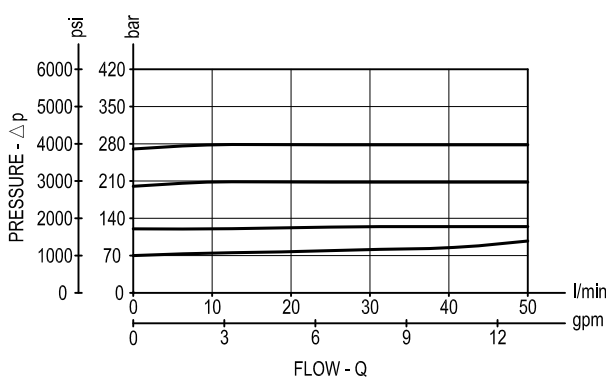

(*) THE VALVE DESIGN CAN TOLERATE OCCASIONAL PEAKS (MAX 140 BAR) FROM 1 TO 2 IN CASE OF HIGH DEMANDING APPLICATION, CONSULT FACTORY

(**) at 80% of pressure setting

(***) Only external seals for 10 valves

Ordering code

OT.M2.01	X	99	Z	W	*
----------	---	----	---	---	---

Relief, direct acting poppet type

Adjustments

= 00 Fixed setting

Special cavity, 730-A

Series 0/A to L
unchanged performances and dimensions

SPRINGS	
Adj. pressure range bar (psi)	
20-70 (290-1000)	= 05
70-120 (1000-1750)	= 10
120-200 (1750-2900)	= 20
200-270 (2900-3900)	= 27
270-320 (3900-4700)	= 32
320-380 (4700-5500)	= 35

Std. SETTING bar (psi) Q=5 l/min (1.3 gpm)

	for Z=05	for Z=10	for Z=20	for Z=27	for Z=32	for Z=35
= 02	20 (290)	80 (1160)	130 (1890)	210 (3050)	280 (4060)	330 (4790)
= 03	30 (440)	90 (1300)	140 (2030)	220 (3190)	290 (4210)	340 (4930)
= 04	40 (580)	100 (1450)	150 (2180)	230 (3340)	300 (4350)	350 (5080)
= 05	50 (730)	110 (1600)	160 (2320)	240 (3480)	310 (4500)	360 (5220)
= 06	60 (870)	120 (1740)	170 (2470)	250 (3630)	320 (4640)	370 (5370)
= 07	70 (1020)		180 (2610)	260 (3770)		380 (5510)
= 08			190 (2760)	270 (3920)		
= 09			200 (2900)			

Type	Material number
OTM201009905020	R931002361
OTM201009905030	R931002362
OTM201009905040	R931002363
OTM201009905050	R931002364
OTM201009905060	R931002365
OTM201009905070	R931002366
OTM201009910020	R931002367
OTM201009910030	R931002369
OTM201009910040	R931002370
OTM201009910050	R931002371
OTM201009910060	R931002372
OTM201009920020	R931002373
OTM201009920030	R931002374
OTM201009920040	R931000034
OTM201009920050	R931002375
OTM201009920060	R931002376
OTM201009920070	R931002377
OTM201009920080	R931002378
OTM201009920090	R901170599
OTM201009927020	R931002380

Type	Material number
OTM201009927030	R931002381
OTM201009927040	R931002382
OTM201009927050	R931002383
OTM201009927060	R931002384
OTM201009927070	R931002385
OTM201009927080	R931002386
OTM201009932020	R931002387
OTM201009932030	R931002388
OTM201009932040	R931002389
OTM201009932050	R931002390
OTM201009932060	R931002391
OTM201009935020	R931002392
OTM201009935030	R931002394
OTM201009935040	R931002395
OTM201009935050	R931002396
OTM201009935060	R931002397
OTM201009935070	R931002398