

## 3-Way heavy duty flow control, with pressure compensated, solenoid and load sensing controlled priority flow

A-VRFC3C-VEI-VS-LS

0M.43.21.80 - Y - Z

**RE 18309-63**

Edition: 11.2023

Replaces: 06.2023

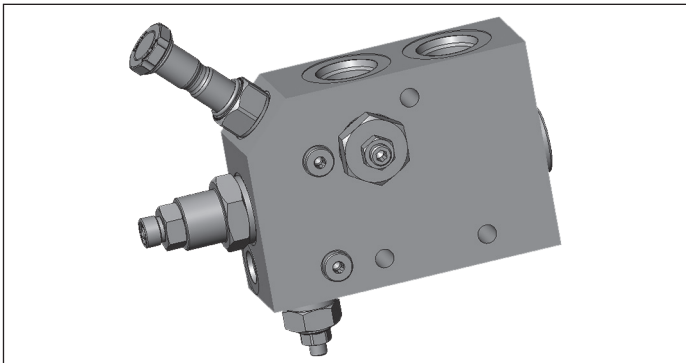

### Description

The flow control valves series “A-VRFC3C-VEI-VS” are 3 way, with one inlet “P” and two outlets “A” and “B”, the first outlet “A” being priority, pressure compensated type, with pressure relief valve and available on demand through a solenoid cartridge; the second outlet “B” is the by-pass for all flow in excess of what demanded by priority. Both flows from “A” and “B” ports can be employed to power different functions of the machine. A pressure signal “LS” from the valve is delivered to the load sensing circuit to increase the pump flow in order to match the requirement. These valves provide a simple and efficient way to power hydraulic tools (such as hydraulic hammers) from the existing hydraulic system, without any need to modify the directional control valve. They allow the simultaneous operations, independently from the respective working pressures, of both the hydraulic actuator powered by the priority outlet “A”, and of the normal functions of the machine (traction, slewing, cylinder motions, etc.) supplied by the main directional valve through the by-pass outlet “B”.

### Technical data

Max. operating pressure	350 bar (5000 psi)
Max. priority line pressure: limited by relief valve (6). See “priority pressure range”	
Back pressure at T port	max. 1.5 bar (20 psi)
Drain from T, with solenoid valve non-energized	up to 1.5 l/min. (0.4 gpm)
Weight	See “Dimensions”
Manifold material	Zinc plated steel
Fluid	Mineral oil (HL, HLP) according to DIN 51524
Fluid temperature range	-20 °C to 80 (-4 to 176 °F)
Viscosity range	20 to 380 mm <sup>2</sup> /s (cSt)
Recommended degree of fluid contamination	Class 19/17/14 according to ISO 4406
Other technical data	see data sheet 18350-50

Note: for applications outside these parameters, please consult us.

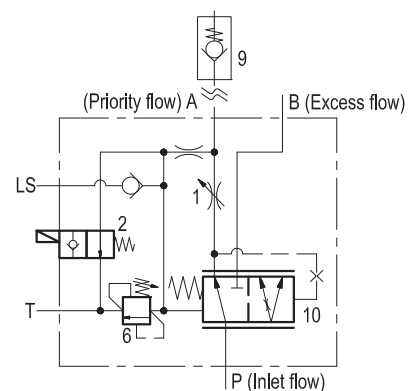

**Ordering code**

<b>0M.43.21.80</b>	<b>Y</b>	<b>Z</b>
--------------------	----------	----------

3-Way heavy duty flow control,  
with pressure compensated, solenoid and  
load sensing controlled priority flow

Priority pressure range		
Adj. pressure range bar (psi)	Pres. increase bar/turn (psi/turn)	Std. setting Q=5 (l/min.) bar (psi)
<b>20</b> 200-350 (2900-5000)	167 (2422)	200 (2900)
<b>35</b> 350-460 (5000-6670)	228 (3306)	350 (5000)

Note: the spare part is delivered with a different setting from the setting of the cartridges used in the block; please refer to cartridge valves datasheet for standard setting data and bar adjustment for each turn of the screw.

	Port sizes		Regulated priority flow	
	P - A	T - LS	l/min (gpm) max	l/min (gpm) per turn
	<b>57</b>	1 1/6-12 UN-2B	9/16-18 UNF	140 (37)

Tamper resistant cap  
ordering code 11.04.23.002  
Mat. no. R930000752



Type	Material number
0M4321805720000	R930005433
0M432180573500A	R930067650

Type	Material number

Characteristic curves

	Priority flow vs pressure	By-pass line pressure drop
--	---------------------------	----------------------------

Version

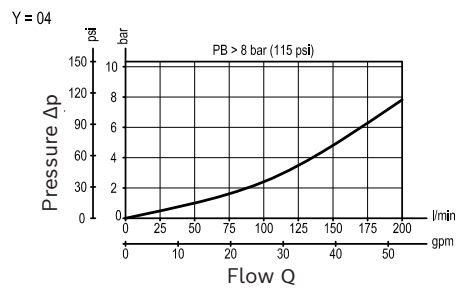
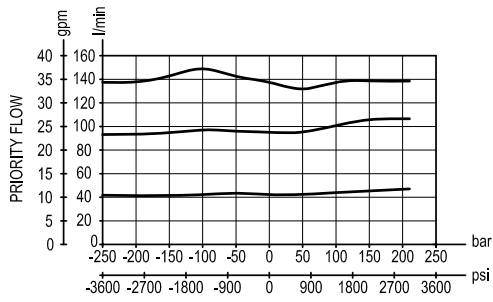

**Dimensions**

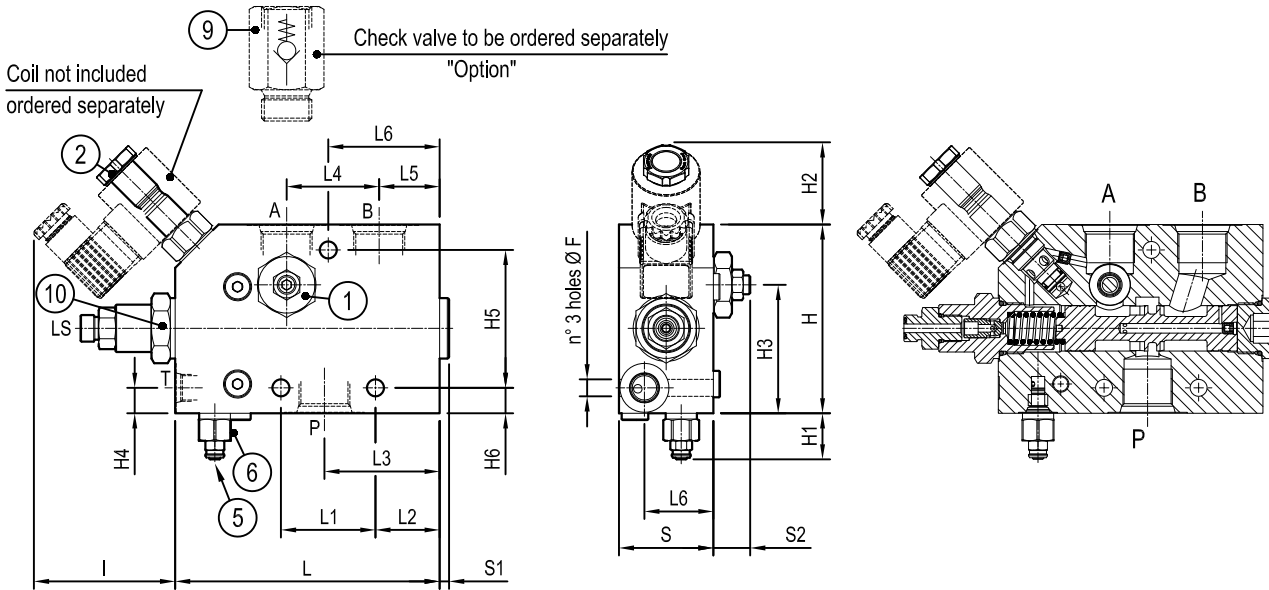

29 (1.14)	5 (0.2)	50 (1.97)	36.5 (1.44)	32 (1.26)	49 (1.93)	61 (2.4)	34 (1.34)	50 (1.97)	140 (5.51)	75 (2.95)	13.5 (0.53)	73 (2.87)	13.5 (0.53)	68 (2.68)	42 (1.65)	25 (0.98)	100 (3.93)	9 (0.35)	1 1/16-12 UN-2B	6 (13)
S2	S1	S	L6	L5	L4	L3	L2	L1	L	I	H6	H5	H4	H3	H2	H1	H	F	Port sizes	Weight kg (lbs)

**Fitting and connections**

When positioning and tightening the valve, avoid any deflection of the body which could prevent the internal spool from sliding freely and impair the metering performance; it is recommended to use the 3 available fixation holes as locating points and to fit 3 equal spacers (metal washers), one on each point, between the valve body and the supporting structure.

Connections to the hydraulic system:

- Port “P” (inlet) to the main line from the pump.
- Port “A” (priority outlet) to the line feeding the hydraulic hammer, or the attachment. Important: for the correct metering of the compensating spool the priority outlet shall be always pressurized, with a back-pressure of at least 8-9 bar (115-130 psi); if necessary, fit a check valve with the needed cracking pressure.
- Port “B” (by-pass, or excess flow outlet) to the line delivering the oil to the main directional valve.
- Port “T” to a tank line. It is absolutely necessary that port “T” is connected to a low pressure tank line, 1-1.5 bar max (15-22 psi max).
- Port “LS” to the load sensing line

**Sleeve type check valves**

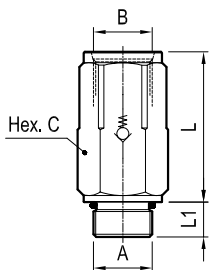

Port sizes A - B	Cracking pressure bar (psi)	Dimensions mm (inches)			Ordering code
		C	L	L1	
1 1/16-12 UN-2B	8 (115)	36 (1.42)	69 (2.72)	16 (0.63)	043117005701000 R930000453

**Adjustment of priority flow**

The volume of priority flow from port “A” can be easily modified by turning the screw (1): the flow increases by turning the screw counter-clockwise and, once adjusted to the desired level, it remains constant independently from the working pressure.

**Adjustment of maximum priority pressure**

The maximum pressure in the priority line “A” can be adjusted by turning the screw (5) of the small relief cartridge (6) which controls the maximum pressure in the chamber (3): when this “pilot” cartridge opens, the pressure in chamber (3) drops and the priority flow is stopped. Note: the relief cartridge (6) controls only the maximum pressure in the priority outlet “A”, and does not control the pressure in the by-pass and main line: the main line must be protected by another relief valve, capable to discharge the full oil flow.

**COILS**

Ordering code: **OD.02.36 - X - Y - Z**

Attention: indicated coils fit every hammer valve versions

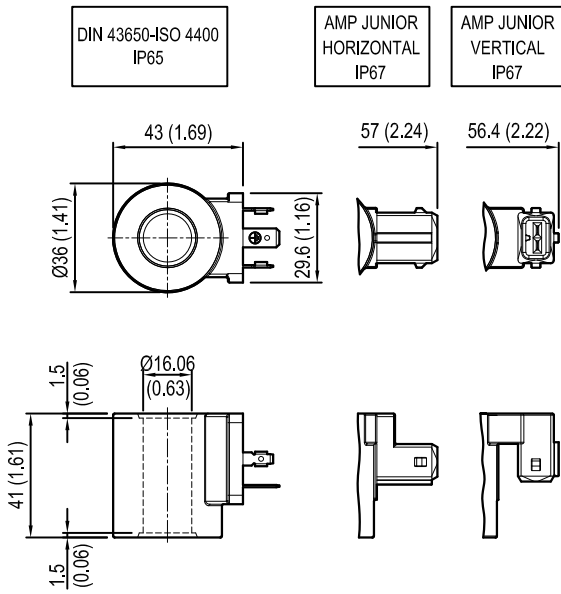

**TECHNICAL DATA**

Weight: 0.18 kg (0.40 lbs)

Power: 20 W

Heat insulation Class H: 180°C (356°F)

Ambient temperature range: -30/+90°C (-22/+194°F)

Further performance limits in terms of temperature and voltage fluctuations: please refer to data sheet of the solenoid valve where D36 coil is mounted.

X	Y	Connections	Circuit	Voltage
01	30	DIN 43650 - ISO 4400	Standard	DC
07	30	AMP JUNIOR H	Standard	DC
07	3P	AMP JUNIOR V	Standard	DC
14	30	DIN 43650 - ISO 4400	Bidirectional Diode	DC
15	30	AMP JUNIOR H	Bidirectional Diode	DC
15	3P	AMP JUNIOR V	Bidirectional Diode	DC

[ mm / Inches ]

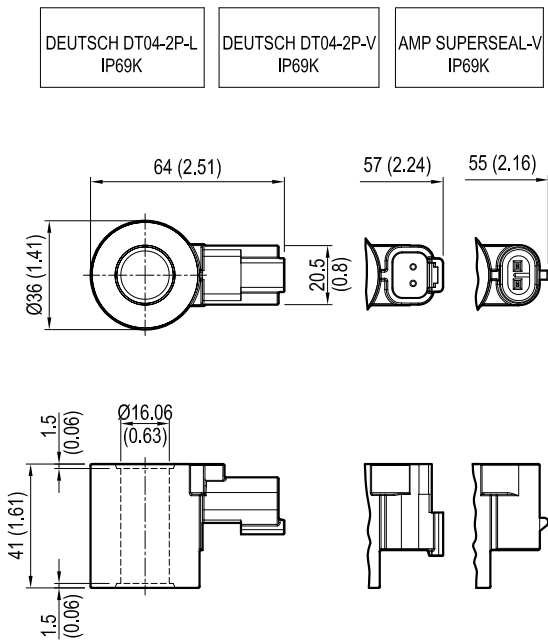

X	Y	Connections	Circuit	Voltage
20	30	DEUTSCH DT04-2P-L	Standard	DC
20	3P	DEUTSCH DT04-2P-V	Standard	DC
30	3P	AMP SUPERSEAL-V	Standard	DC
22	30	DEUTSCH DT04-2P-L	Bidirectional Diode	DC
22	3P	DEUTSCH DT04-2P-V	Bidirectional Diode	DC
32	3P	AMP SUPERSEAL-V	Bidirectional Diode	DC

[ mm / Inches ]

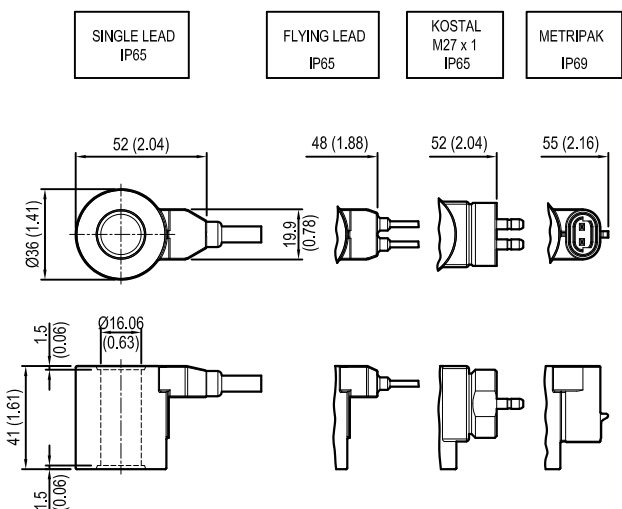

[ mm / Inches ]

X	Y	Connections	Circuit	Voltage
0G	03	SINGLE LEAD *	Standard	DC
02	03	FLYING LEAD **	Standard	DC
03	30	KOSTAL M27x01	Standard	DC
40	3P	METRIPAK	Standard	DC
0H	03	SINGLE LEAD *	Bidirectional Diode	DC
23	03	FLYING LEAD **	Bidirectional Diode	DC
12	30	KOSTAL M27x01	Bidirectional Diode	DC
41	3P	METRIPAK	Bidirectional Diode	DC

\* Length 300mm (11.8 inches). Ext. diameter 6.3mm (0.25 inches). External and internal Sheath Silicone rubber.  
 \*\* Length 300mm

Note: Single lead and Flying lead coil also available with 1000 mm length; ordering code with Y=10 in place of Y=03

Z	Voltage V	Resistance Ohm (±7%)	Power W	Current A	
	Nominal	aT = 20 °C (68 °F)		I Max.	I Nom.
OB	12 DC	7.4	20	1.67	1.04
OC	24 DC	28.4	20	0.83	0.54
OD	48 DC	106.5	20	0.42	0.29
OU*	96 DC	451	20	0.21	0.14
AH*	205 DC	2062	20	0.10	0.06

\* OU and AH versions especially designed in cases of AC supply voltage (respectively for 110AC and 220 AC) to be used in conjunction with connector with circuit including wave rectifier. Ambient temperature range for OU and AH versions: -30°C / + 75°C

Note: diode available only for 12 V DC and 24 V DC coils. Diode set at 27 V DC for 12 V DC coil and at 39 V DC for 24 V DC coil.

Note: please refer to data sheet RE 18325-90 for coils and connectors readily available and for further details.

**SPARE PARTS**

SOLENOID CARTRIDGE	
Port size	Ordering code
0M.43.21.80.57.20	OD150218A000000
0M.43.21.80.57.35	R930059442

RELIEF CARTRIDGE	
Port size	Ordering code
0M.43.21.80.57.20	041158039946000 R901098895
0M.43.21.80.57.35	041158039935000 R901113597

**Bosch Rexroth Oil Control S.p.A.**  
 Via Leonardo da Vinci 5  
 P.O. Box no. 5  
 41015 Nonantola – Modena, Italy  
 Tel. +39 059 887 611  
 Fax +39 059 547 848  
 compact-hydraulics-pib@boschrexroth.com  
 www.boschrexroth.com/compacthydraulics

© This document, as well as the data, specifications and other information set forth in it, are the exclusive property of Bosch Rexroth Oil Control S.p.a.. It may not be reproduced or given to third parties without its consent. The data specified above only serve to describe the product. No statements concerning a certain condition or suitability for a certain application can be derived from our information. The information given does not release the user from the obligation of own judgment and verification. It must be remembered that our products are subject to a natural process of wear and aging. Subject to change.