

Check and metering valve

A-VBC-90-SX

08.47.96 - X - Y - Z

RE 18309-04

Edition: 09.2022

Replaces: 03.2016

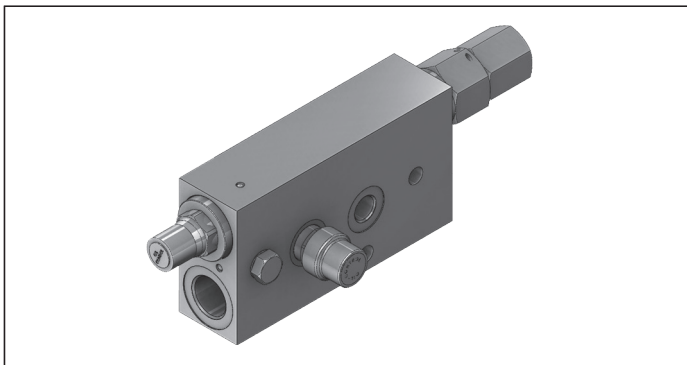

Technical data

Max. operating pressure	420 bar (6000 psi)
Max. flow	100 l/min. (26 gpm)
Weight	2.4 kg (5.3 lbs)
Manifold material	Zinc plated steel
Fluid	Mineral oil (HL, HLP) according to DIN 51524
Fluid temperature range	-30 °C to 100 (-22 to 212 °F)
Viscosity range	10 to 500 mm ² /s (cSt)
Recommended degree of fluid contamination	Class 19/17/14 according to ISO 4406

This valve is designed to be pipe mounted on boom cylinders of hydraulic excavators, and, with specific adjustments, it can become part of load holding and load lowering systems designed to comply with ISO Standard 8643 (hose burst protection).

Note: the Tank vented port must be connected to a "low pressure tank line" (to the joystick tank line, or to tank directly).

The Factory sealed "E" screw can be used for Emergency spool opening and boom lowering, in case of pilot pressure failure; once the emergency boom lowering is completed, the "E" screw must be restored to its original position and locked.

Other technical data see data sheet 18350-50

Note: for applications outside these parameters, please consult us.

Description

Upstream flow (V2 - C2) to the cylinder is free through a check valve, and reverse flow (C2 - V2) is locked/metered by a leak free spool (1) which provides fine metering in the initial opening stroke. The spool, normally held closed by an adjustable spring force, is remotely controlled by joystick pilot pressure; the pilot pressure required to move the spool is load independent because the spring is vented to Tank. The valve includes a small relief cartridge (2) which senses C2 pressure and opens under overload or shock conditions in order to pilot wide open the metering spool and to allow cylinder pressure to be relieved downstream through the main hose (V2) and through the main control valve.

Note: port identified with M are not protected with calibrated orifice but in direct connection with pressure channels.

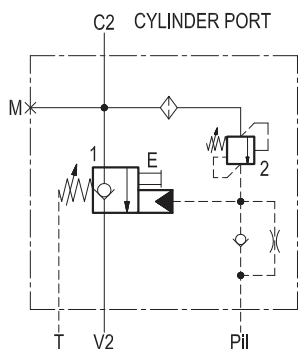

Characteristic curve

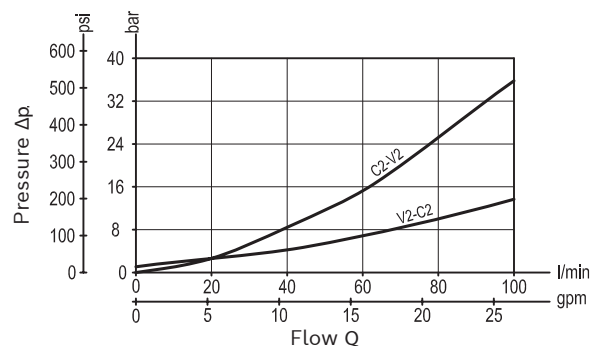

Ordering code

08.47.96	X	Y	Z
-----------------	----------	----------	----------

Check and metering valve

Adjustments

00 Inner hex. socket screw protected by locking nut

Port sizes	V2-C2	Pil	T	M
03	G 1/2	G 1/4	G 1/4	G 1/8

		SPRINGS		
		Adj. pressure range bar (psi)	Pres. increase bar/turn (psi/turn)	Std. setting bar (psi)
40	Valve 1	7-15 (100-220)	4 (58)	7.5 (109) "cracking"
	Valve 2	350-460 (5000-6600)	228 (3306)	350 (5000) "5 l/min"

Tamper resistant cap
ordering code 11.04.31.001
Mat. no. R930000777
for Valve 2



Preferred types

Type	Material number
08479600034000B	R987274543

Type	Material number

Dimensions

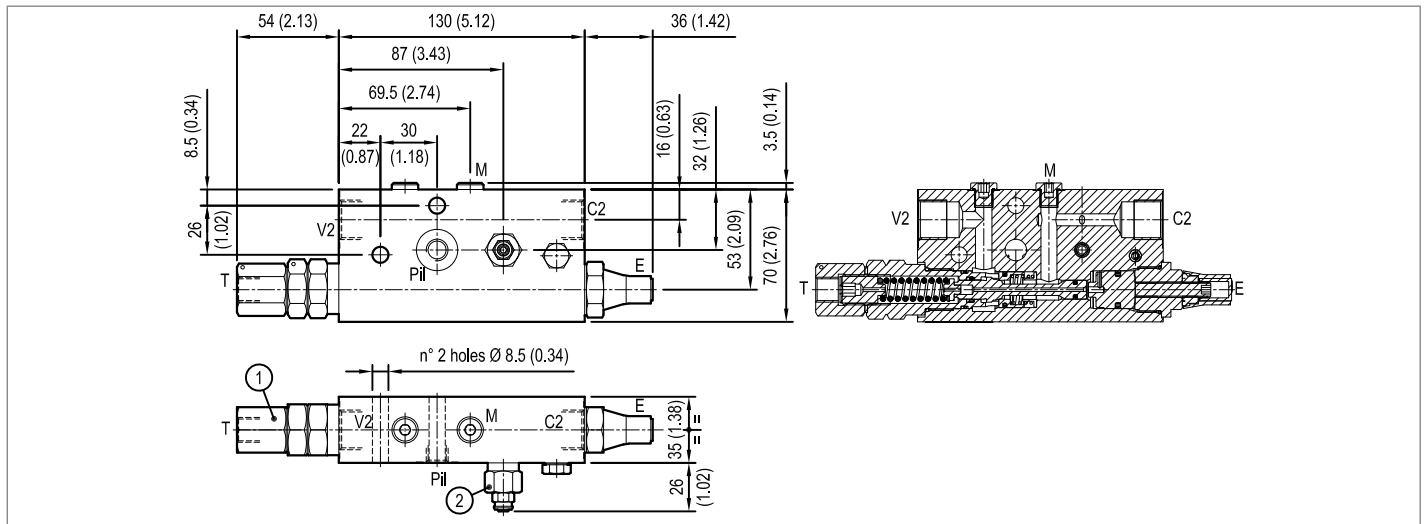

Bosch Rexroth Oil Control S.p.A.

Via Leonardo da Vinci 5
P.O. Box no. 5
41015 Nonantola – Modena, Italy
Tel. +39 059 887 611
Fax +39 059 547 848
compact-hydraulics-pib@boschrexroth.com
www.boschrexroth.com/compacthydraulics

© This document, as well as the data, specifications and other information set forth in it, are the exclusive property of Bosch Rexroth Oil Control S.p.a.. It may not be reproduced or given to third parties without its consent. The data specified above only serve to describe the product. No statements concerning a certain condition or suitability for a certain application can be derived from our information. The information given does not release the user from the obligation of own judgment and verification. It must be remembered that our products are subject to a natural process of wear and aging. Subject to change.