

# Dual counterbalance, with regenerative function

VBSO-DE-CR-33

05.44.13 - X - Y - Z

**RE 18307-92**

Edition: 03.2016

Replaces: 11.2015

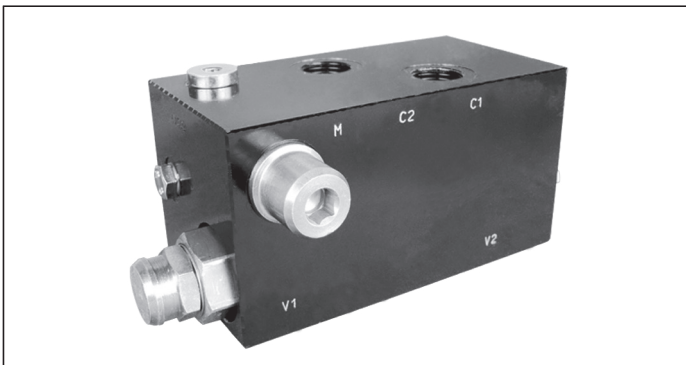

## Description

It provides static and dynamic control of load by regulating the flow IN and OUT of the cylinder, through ports C2 and C1. This valve module includes a pilot assisted counterbalance (2) on the line C2-V2 for control of the full bore side of the cylinder, a check valve between V1 and C1 which allows flow into the annular side and locks in reverse direction, a pilot assisted by-pass counterbalance “fully vented type” (1) which feeds into the full bore (C2) the flow coming out from the annular side (C1) in order to increase the extension speed. The valve (1) is internally vented into V1 which acts as “Tank” line during cylinder extension. The pilot line for the valve (1) has a one way adjustable cross-over drain for hydraulic damping.

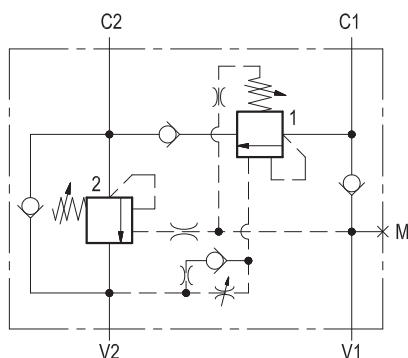

## Technical data

Operating pressure	up to 210 bar (3000 psi)
Max. flow	100 l/min. (26 gpm)
Weight	2.6 kg (5.7 lbs)
Manifold material	Anodized aluminium
Note: aluminium bodies are often strong enough for operating pressures exceeding 210 bar (3000 psi), depending from the fatigue life expected in the specific application. If in doubt, consult our Service Network.	
Fluid	Mineral oil (HL, HLP) according DIN 51524
Fluid temperature range	-30 °C to 100 (-22 to 212 °F)
Viscosity range	10 to 500 mm <sup>2</sup> /s (cSt)
Recommended degree of fluid contamination	Class 19/17/14 according to ISO 4406
Other technical data	see data sheet 18350-50
Relief setting: at least 1.3 times the highest expected load.	

Note: for applications outside these parameters, please consult us.

## Characteristic curve

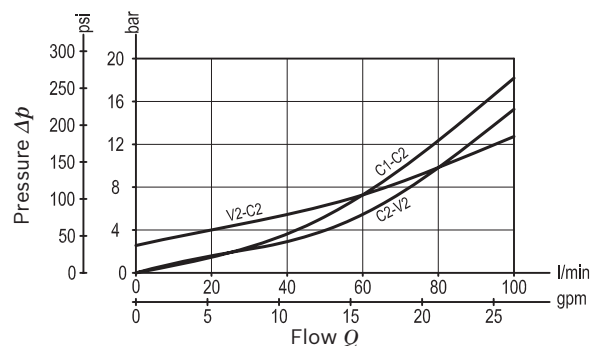

**Ordering code**

<b>05.44.13</b>	<b>X</b>	<b>Y</b>	<b>Z</b>
-----------------	----------	----------	----------

Dual counterbalance,  
with regenerative function

Pilot ratio

**03** 4:1

Port sizes	V1 - V2	C1 - C2	M
<b>03</b>	G 1/2	G 1/2	G 1/4

		SPRINGS		
		Adj. pressure range bar (psi)	Pres. increase bar/turn (psi/turn)	Std. setting Q=5 (l/min) bar (psi)
<b>35</b>	Valve 1	150-350 (2175-5000)	110 (1595)	350 (5000)
	Valve 2	150-350 (2175-5000)	110 (1595)	350 (5000)

Tamper resistant cap  
ordering code 11.04.30.001  
Mat. no. R930005194

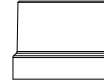

**Preferred types**

Type	Material number
05441303033500F	R930007159

Type	Material number

**Dimensions**

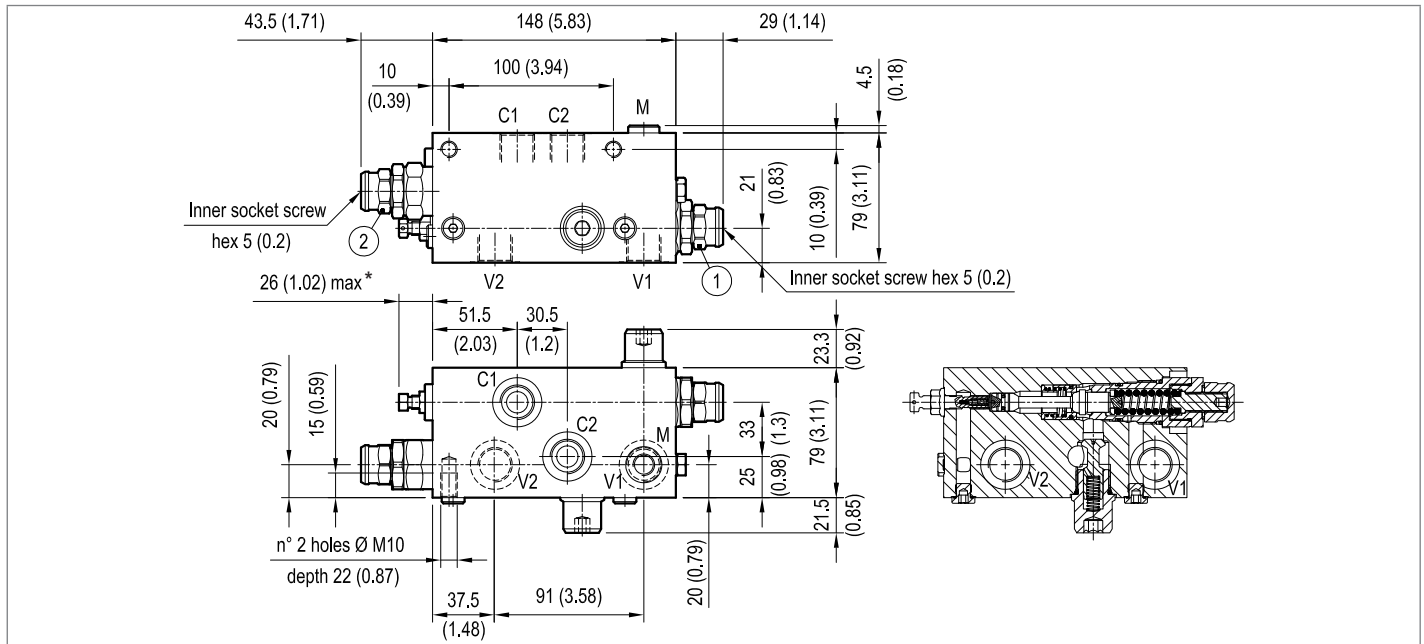

\* The adjusting screw can be completely unscrewed. Do not exceed the indicated protrusion range of the adjusted screw.

**Bosch Rexroth Oil Control S.p.A.**

Via Leonardo da Vinci 5  
P.O. Box no. 5  
41015 Nonantola - Modena, Italy  
Tel. +39 059 887 611  
Fax +39 059 547 848  
compact-hydraulics-pib@boschrexroth.com  
www.boschrexroth.com/compacthydraulics

© This document, as well as the data, specifications and other information set forth in it, are the exclusive property of Bosch Rexroth Oil Control S.p.a.. It may not be reproduced or given to third parties without its consent. The data specified above only serve to describe the product. No statements concerning a certain condition or suitability for a certain application can be derived from our information. The information given does not release the user from the obligation of own judgment and verification. It must be remembered that our products are subject to a natural process of wear and aging. Subject to change.