

# Dual counterbalance

VBSO-DE-FC2

05.42.06 - X - Y - Z

**RE 18307-64**

Edition: 03.2016

Replaces: 04.2010

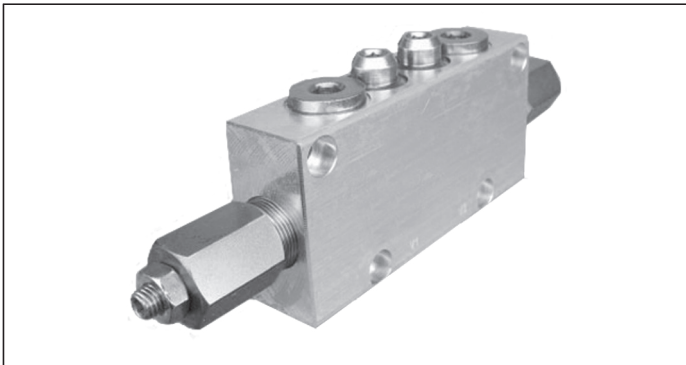

## Description

It provides static and dynamic control of load by regulating the flow IN and OUT of the actuator, through ports C1 and C2. This valve module includes 2 sections, each one composed by a check and a relief valve pilot assisted by pressure in the opposite line: the check section allows free flow into the actuator, then holds the load against reverse movement; with pilot pressure applied at the line across, the pressure setting of the relief is reduced in proportion to the stated ratio until opening and allowing controlled reverse flow. Back-pressure at V1 or V2 is additive to the pressure setting in all functions. For better safety and compact assembly, the C1 and C2 ports are gasket mounted directly on the actuator.

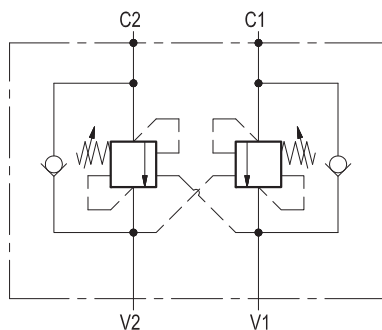

## Technical data

Operating pressure	up to 210 bar (3000 psi)
Max. flow	see performance graph
Weight	see "Dimensions"
Manifold material	Aluminium
Note: aluminium bodies are often strong enough for operating pressures exceeding 210 bar (3000 psi), depending from the fatigue life expected in the specific application. If in doubt, consult our Service Network.	
Flange seal kit (03) <sup>1)</sup>	E00000000000008 (R930004538)
Flange seal kit (04) <sup>2)</sup>	E00000000000020 (R930000144)
Fluid	Mineral oil (HL, HLP) according DIN 51524
Fluid temperature range	-30 °C to 100 (-22 to 212 °F)
Viscosity range	5 to 800 mm <sup>2</sup> /s (cSt)
Recommended degree of fluid contamination	Class 19/17/14 according to ISO 4406
Other technical data	see data sheet 18350-50
Relief setting: at least 1.3 times the highest expected load.	

Note: for applications outside these parameters, please consult us.

<sup>1)</sup> Seals for 10 valves

<sup>2)</sup> Seals for 5 valves

## Characteristic curve

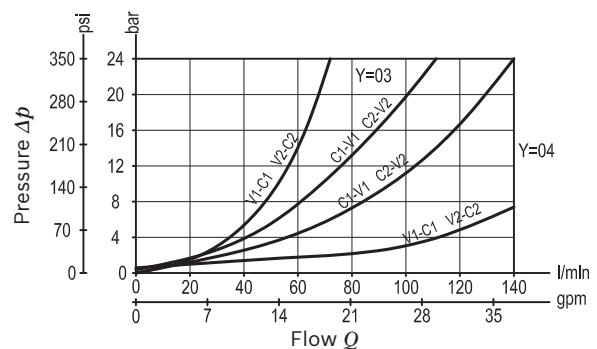

Ordering code

05.42.06	X	Y	Z
----------	---	---	---

Dual counterbalance

Pilot ratio

03 8.2 : 1

10 3.2 : 1

Port sizes	V1 - V2	C1 - C2
03	G 1/2	Ø 10 (0.39)
04	G 3/4	Ø 14 (0.55)

35	SPRINGS		
	Adj. pressure range bar (psi)	Pres. increase bar/turn (psi/turn)	Std. setting Q=5 (l/min) bar (psi)
	120-350 (1750-5000)	106 (1537)	350 (5000)

Preferred types

Type	Material number
05420603033500A	R930001803
05420603043500A	R930001805

Type	Material number
05420610033500A	R930001806
054206100435000	R930001807

Dimensions

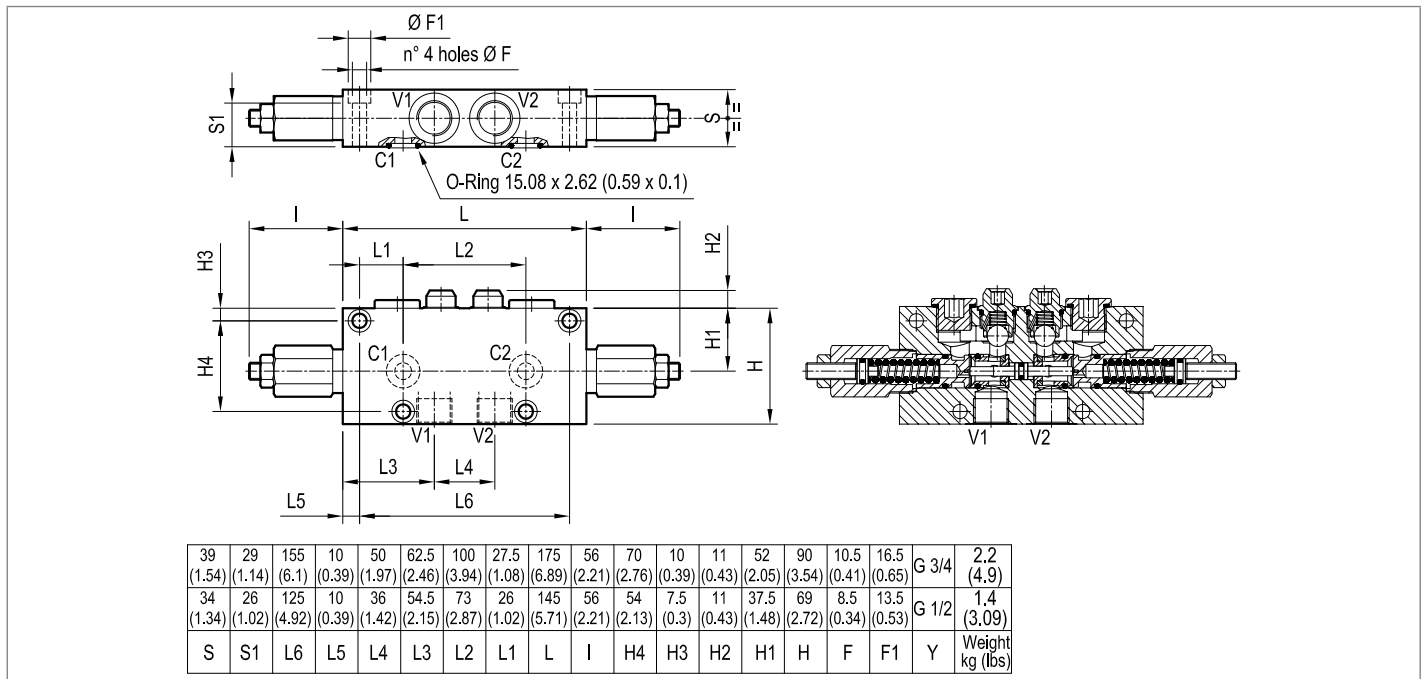

Bosch Rexroth Oil Control S.p.A.

Via Leonardo da Vinci 5  
 P.O. Box no. 5  
 41015 Nonantola - Modena, Italy  
 Tel. +39 059 887 611  
 Fax +39 059 547 848  
 compact-hydraulics-pib@boschrexroth.com  
 www.boschrexroth.com/compacthydraulics

© This document, as well as the data, specifications and other information set forth in it, are the exclusive property of Bosch Rexroth Oil Control S.p.a.. It may not be reproduced or given to third parties without its consent. The data specified above only serve to describe the product. No statements concerning a certain condition or suitability for a certain application can be derived from our information. The information given does not release the user from the obligation of own judgment and verification. It must be remembered that our products are subject to a natural process of wear and aging. Subject to change.