

Sequence, direct acting poppet type, compensated

VSQ-CC-30

05.21.11 - X - Y - Z

RE 18309-87

Edition: 03.2016

Replaces: 04.2010

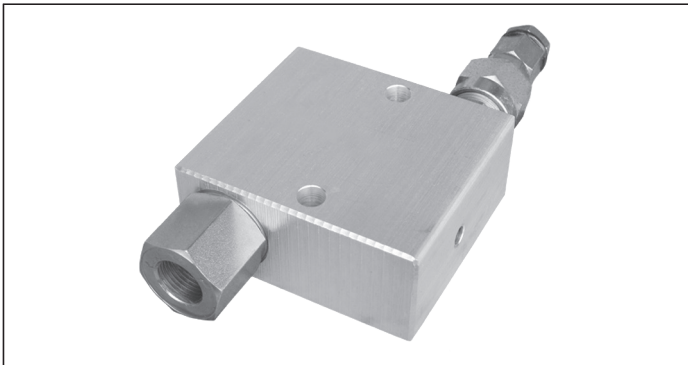

Technical data

Operating pressure	up to 210 bar (3000 psi)
Max. flow	30 l/min. (8 gpm)
For a good performance, the pressure in the secondary circuit should not drop below 20 bar.	
Weight	0.81 kg (1.79 lbs)
Manifold material	Aluminium
Note: aluminium bodies are often strong enough for operating pressures exceeding 210 bar (3000 psi), depending from the fatigue life expected in the specific application. If in doubt, consult our Service Network.	
Fluid	Mineral oil (HL, HLP) according DIN 51524
Fluid temperature range	-30 °C to 100 (-22 to 212 °F)
Viscosity range	10 to 500 mm ² /s (cSt)
Recommended degree of fluid contamination	Class 19/17/14 according to ISO 4406
Other technical data	see data sheet 18350-50

Note: for applications outside these parameters, please consult us.

Description

Initially, the flow goes to a side line connected to V1, not shown here, and energizes a first actuator until pressure increases to meet the selected valve setting; then flow opens the relief cartridge and passes from V1 to C1 energizing the second actuator connected to C1. The valve applies a balanced relief piston allowing relief operation at the valve setting independent of back-pressure at C1. With line pressure equal or higher than setting, after valve opening, the full pressure is transferred from V1 to C1 and to the second actuator. The hydraulic damping of the relief piston provides enhanced stability at all flows. The check valve allows reverse flow, from C1 to V1.

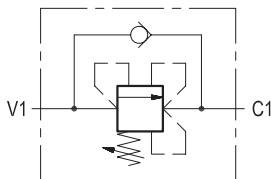

Characteristic curve

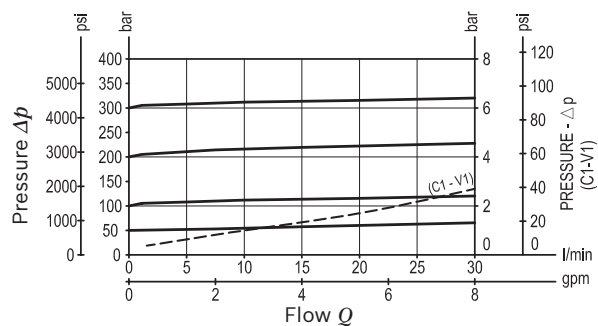

Ordering code

05.21.11	X	Y	Z
-----------------	----------	----------	----------

Sequence
direct acting poppet type, compensated

Adjustments

03 Leakproof inner hex. socket screw



	SPRINGS		
	Adj. pressure range bar (psi)	Pres. increase bar/turn (psi/turn)	Std. setting Q=5 (l/min) bar (psi)
05	5-50 (75-725)	11 (160)	50 (725)
10	30-100 (435-1450)	23 (334)	100 (1450)
20	50-210 (725-3000)	47 (682)	200 (2900)
35	100-350 (1450-5000)	82 (1189)	350 (5000)

Port sizes	V1	C1	
02	G 3/8	G 3/8	
03	G 1/2	G 1/2	

Preferred types

Type	Material number
05211103020500B	R930001429
05211103021000B	R930001430
05211103022000B	R930001431
05211103023500B	R930001432

Type	Material number
05211103030500B	R930001433
05211103031000B	R930001434
05211103032000B	R930001435
05211103033500B	R930001437

Dimensions

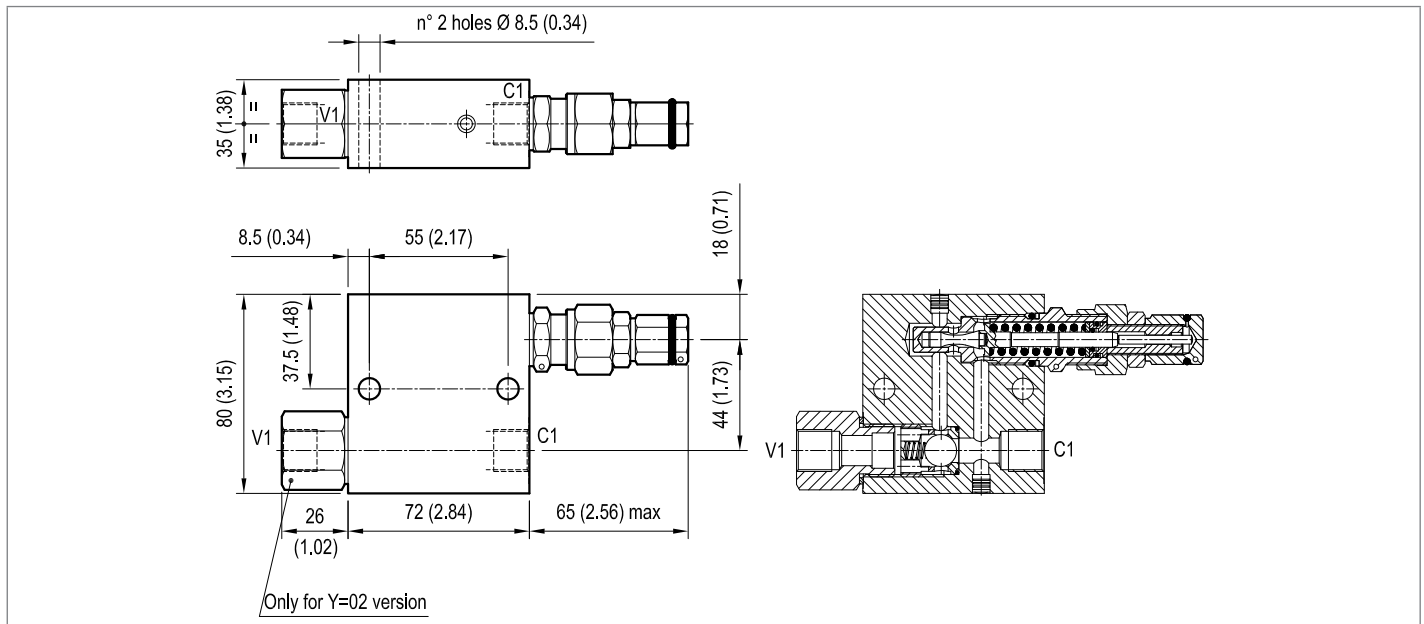

Bosch Rexroth Oil Control S.p.A.

Via Leonardo da Vinci 5
P.O. Box no. 5
41015 Nonantola – Modena, Italy
Tel. +39 059 887 611
Fax +39 059 547 848
compact-hydraulics-pib@boschrexroth.com
www.boschrexroth.com/compacthydraulics

© This document, as well as the data, specifications and other information set forth in it, are the exclusive property of Bosch Rexroth Oil Control S.p.a.. It may not be reproduced or given to third parties without its consent. The data specified above only serve to describe the product. No statements concerning a certain condition or suitability for a certain application can be derived from our information. The information given does not release the user from the obligation of own judgment and verification. It must be remembered that our products are subject to a natural process of wear and aging. Subject to change.