

Counterbalance, relief compensated poppet type differential area Common cavity, Size 10

VBSP-10A

04.54.09 - X - 85 - Z

RE 18320-07

Edition: 07.2023

Replaces: 01.2020

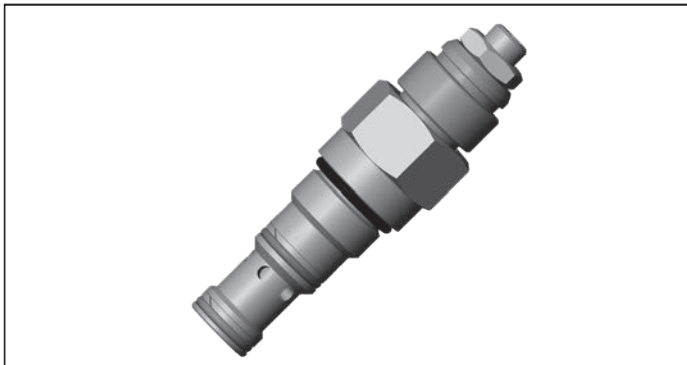

Technical data	
Max. operating pressure	350 bar (5000 psi)
Max. flow	60 l/min (16 gpm)
Max. internal leakage ¹⁾	15 drops/min.
Fluid temperature range	-30 to 100 °C (-22 to 212 °F)
Installation torque	41 - 47 Nm (30 - 35 ft-lbs)
Weight	0.2 kg (0.44 lbs)
MTTFD	150 years see RE 18350-51
Cavity	CA-10A-3C (see data sheet 18325-70)
Adjustment	according to ISO 4413 with sealed adjustment screw to prevent oil leakage during adjustment
Salt spray test	500h according to DIN EN ISO 9227:2017-07
Lines bodies and standard assemblies	Please refer to section "Hydraulic integrated circuit" or consult factory
Seal kit ²⁾	Code: RG10A9010520100 material no: R901111367
Fluids	Mineral-based or synthetics with lubricating properties at viscosities of 10 to 500 mm ² /s (cSt)
Recommended degree of fluid contamination	Nominal value max. 10µm (NAS 8) / ISO 4406 19/17/14
Installation position	No restrictions
Other Technical Data	See data sheet 18350-50

Pressure setting: at least 1.3 times the load induced pressure and maximum 1.5 times catalogue max nominal setting.

- 1) At 70% of pressure setting
- 2) Only external seals for 10 valves

Characteristic curve

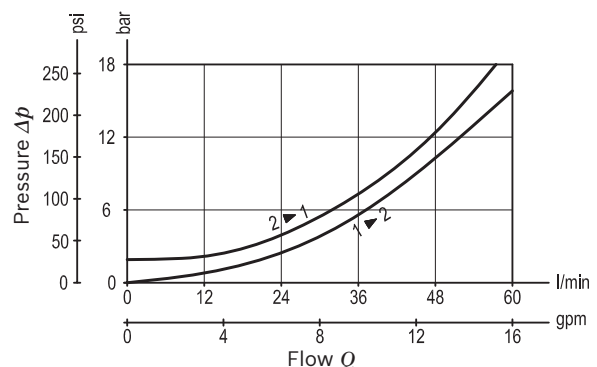

Description

When pressure at 2 rises above the spring bias pressure, the check seat is pushed away from the piston and flow is allowed from 2 to 1. When load pressure at 1 rises above the pressure setting, the direct-acting, differential area relief function is activated and flow is relieved from 1 to 2. With pilot pressure at 3, the pressure setting is reduced in proportion to the stated ratio of the valve, until fully open with free-flow from 1 to 2. The spring chamber is drained to 2. The valve applies a balanced piston design allowing relief operation at the valve setting independent of back-pressure at 2. However, the piloted opening of the valve remains subject to additive pressure at port 2. Valve design prevents spring going solid and complete unscrewing during adjusting.

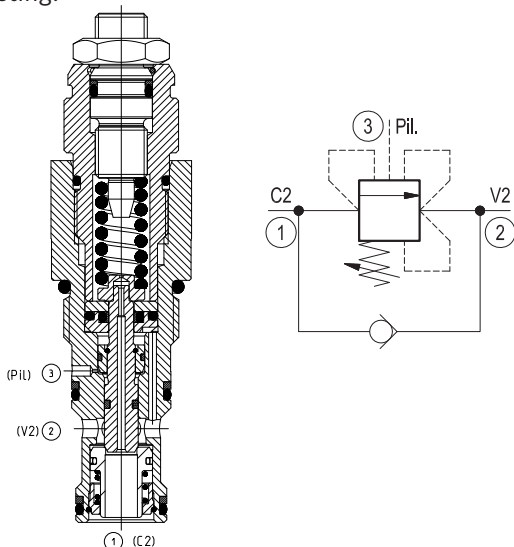

Ordering code

04.54.09	X	85	Z	*	*
-----------------	----------	-----------	----------	----------	----------

Counterbalance, relief compensated, poppet type differential area

Pilot ratio

03 3:1 Without sealed pilot piston

85 Common cavity, Size 10

Series M to Z
unchanged performances and dimensions

00 Standard (Buna)
VO Viton (FKM)

	SPRINGS		
	Adj. press. range bar (psi)	Pressure increase bar/turn (psi/turn)	Std. setting bar (psi) Q=5 l/min
20	70-210 (1000-3000)	135 (1958)	200 (2900)
35	140-350 (2000-5000)	196 (2842)	350 (5000)

Note: Special settings available with optional tamperproof cap. Contact factory authorized representative for ordering code.

Preferred types

Type	Material number
04540903852000M	R930081304
04540903853500M	R930081305

Type	Material number

Dimensions

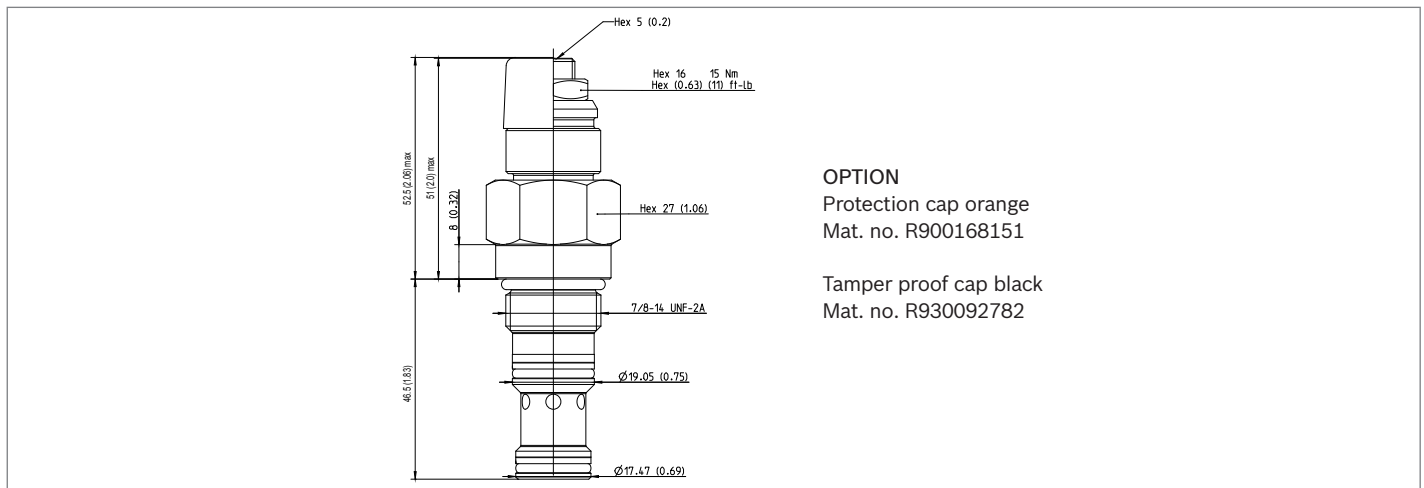

Bosch Rexroth Oil Control S.p.A.

Via Leonardo da Vinci 5
P.O. Box no. 5
41015 Nonantola – Modena, Italy
Tel. +39 059 887 611
Fax +39 059 547 848
compact-hydraulics-cv@boschrexroth.com
www.boschrexroth.com/compacthydraulics

© This document, as well as the data, specifications and other information set forth in it, are the exclusive property of Bosch Rexroth Oil Control S.p.a.. It may not be reproduced or given to third parties without its consent. The data specified above only serve to describe the product. No statements concerning a certain condition or suitability for a certain application can be derived from our information. The information given does not release the user from the obligation of own judgment and verification. It must be remembered that our products are subject to a natural process of wear and aging. Subject to change.