

Counterbalance, standard poppet type differential area, for motor applications Sun cavity interchange, T-17A

VBSN-16U-RF

04.52.47 - X - 47 - Z

RE 18320-31

Edition: 03.2016

Replaces: 07.2015

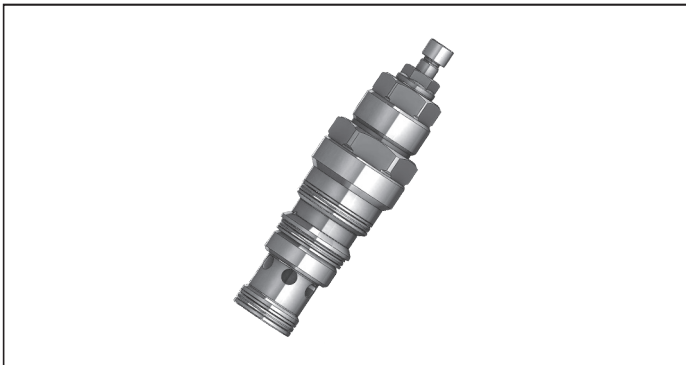

Technical data	
Max. operating pressure	420 bar (6000 psi)
Max. flow	240 l/min (63 gpm)
Max. internal leakage ¹⁾	5 cm ³ /min. (0.31 cu.in./min.)
Fluid temperature range	-30 to 100 °C (-22 to 212 °F)
Installation torque	200 - 215 Nm (147 - 159 ft-lbs)
Weight	0.85 kg (1.87 lbs)
Cavity	SUN T-17A
Lines bodies and standard assemblies	Please refer to section "Hydraulic integrated circuit" or consult factory
Seal kit ²⁾	Code: RG16U9020110100 material no: R930000995
Fluids	Mineral-based or synthetics with lubricating properties at viscosities of 10 to 500 mm ² /s (cSt)
Recommended degree of fluid contamination	Nominal value max. 10µm (NAS 8) / ISO 4406 19/17/14
Installation position	No restrictions
Other Technical Data	See data sheet 18350-50

Pressure setting: at least 1.3 times the load induced pressure.

- 1) At 70% of pressure setting
- 2) Only external seals for 10 valves

Characteristic curve

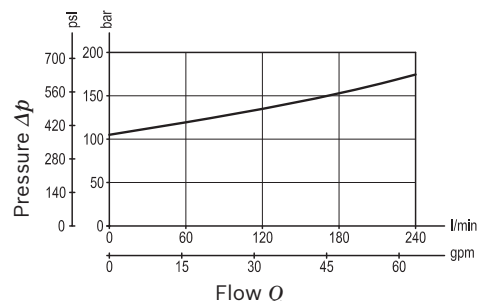
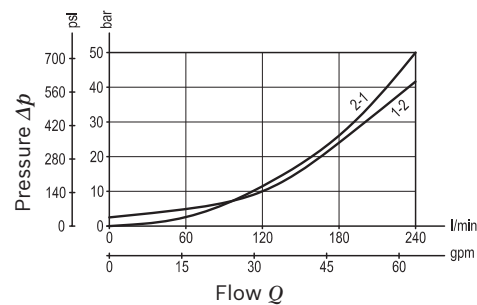

Description

When pressure at 2 rises above the spring bias pressure, the check seat is pushed away from the piston and flow is allowed from 2 to 1. When load pressure at 1 rises above the pressure setting, the direct-acting, differential area relief function is activated and flow is relieved from 1 to 2. With pilot pressure at 3, the pressure setting is reduced in proportion to the stated ratio of the valve, until fully open with free-flow from 1 to 2. Any back-pressure at 2 is additive to the pressure setting in all functions. The special design of the poppet allows low delta P during relief function and makes the valve especially suitable for hydraulic motors control. Valve especially designed for motor applications, where it is requested a low delta P during relief function.

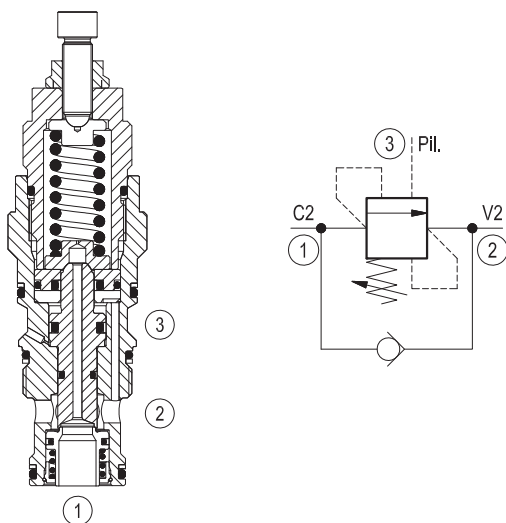

Ordering code

04.52.47	X	47	Z	00	*
-----------------	----------	-----------	----------	-----------	----------

Counterbalance, standard poppet type differential area, for motor applications

Series O/A to L unchanged performances and dimensions

Version and options standard

Pilot ratio

10 8:1

SPRINGS			
	Adj. press. range bar (psi)	Pressure increase bar/turn (psi/turn)	Std. setting bar (psi) Q=5 l/min
35	100-350 (1450-5000)	41 (595)	350 (5000)

Note: Special settings available. Contact factory authorized representative for ordering code.

47 SUN cavity interchange, T-17A

Preferred types

Type	Material number
04524710473500A	R930056511

Type	Material number

Dimensions

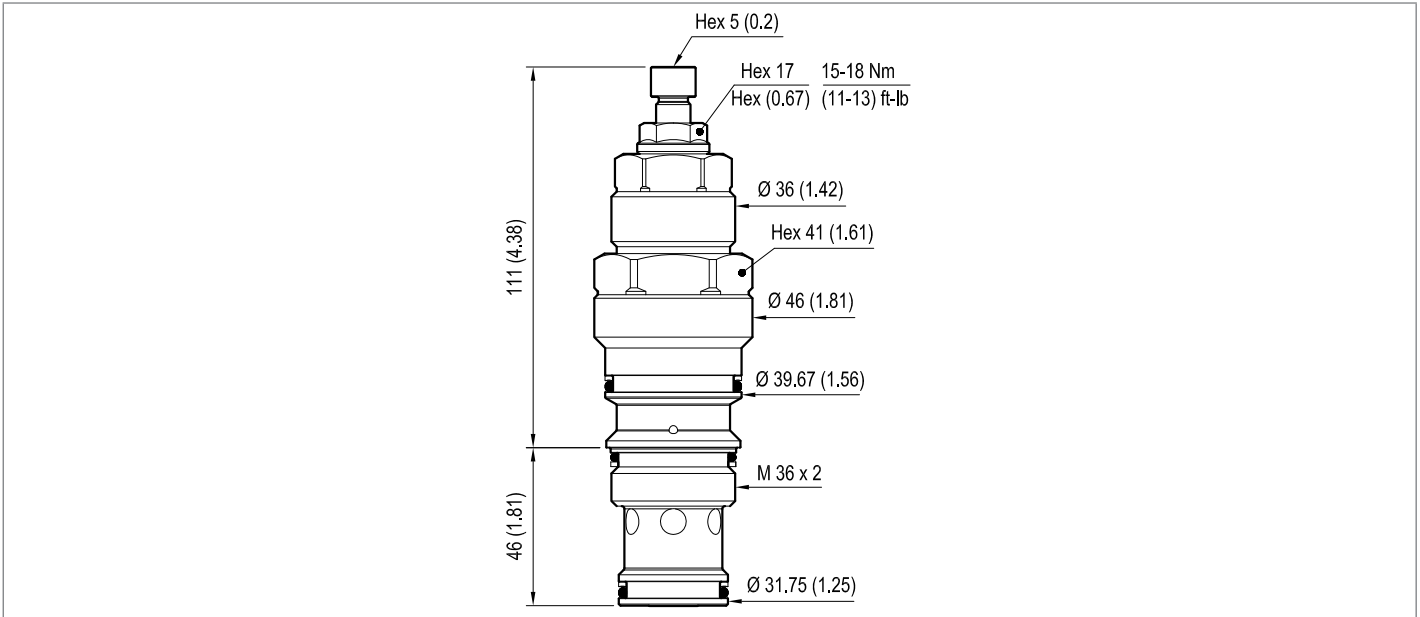

Bosch Rexroth Oil Control S.p.A.

Via Leonardo da Vinci 5
 P.O. Box no. 5
 41015 Nonantola – Modena, Italy
 Tel. +39 059 887 611
 Fax +39 059 547 848
 compact-hydraulics-cv@boschrexroth.com
 www.boschrexroth.com/compacthydraulics

© This document, as well as the data, specifications and other information set forth in it, are the exclusive property of Bosch Rexroth Oil Control S.p.a.. It may not be reproduced or given to third parties without its consent. The data specified above only serve to describe the product. No statements concerning a certain condition or suitability for a certain application can be derived from our information. The information given does not release the user from the obligation of own judgment and verification. It must be remembered that our products are subject to a natural process of wear and aging. Subject to change.